

Hydrant Systems

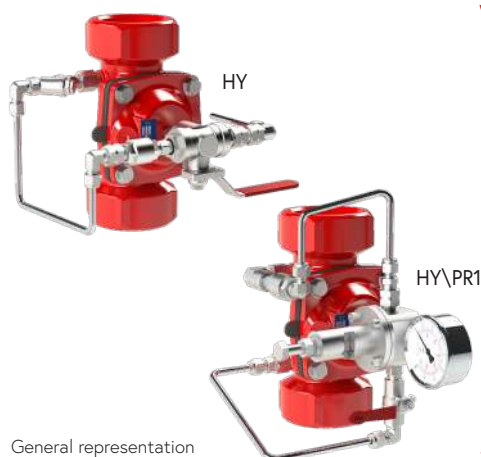

General representation

Fire
Protection

Description

HY Hydrant Valve: Manually controlled hydrant valve, actuated by the pipeline pressure. When the activation valve is turned to the open position, it opens gradually to prevent a sudden pressure rise in the hose. It closes drip tight when the activation valve is turned back to the closed position, reducing the risk of water hammer damage.

HY\PR1 Hydraulic Pressure Reducing Hydrant Valve: Manually controlled, pressure reducing hydrant valve, actuated by the pipeline pressure. When the activation ball valve is turned to the open position, it opens gradually to prevent sudden pressure rise in the hose, up to a predetermined set point. It closes drip tight when the activation valve is turned back to the closed position, reducing the risk of water hammer damage.



Features & Benefits

- Effortless open/close actuation
- Controlled response
- Straightforward & reliable design
- Easy installation & maintenance
- Applicable for water, seawater & foam



Certification & Compliance

Lloyd's Register Approval



ANSI FCI 70-2 Class VI seat leakage class



Typical Applications

Automatic or Manual Actuated Fire
Suppression Systems

Petrochemical, Oil & Gas Installations

Power Generation, Transformer &
Transmission Plants

Flammable Storage

Hangers & Airport Terminals

Onshore/Offshore



Operation

The basic control valve [1] used in this hydrant system is a direct-sealing elastomeric diaphragm, hydraulically operated control valve engineered specifically for fire protection systems.

In the standby position, the hydrant valve is held closed by the upstream water pressure, trapped in the valve's control chamber.

OCV HY: The water pressure enters the control chamber through a Y-type strainer [2], a check valve [3], a restrictor [4] and a 3-way ball valve [5].

OCV HY\PR1: The water pressure enters the control chamber through an inline strainer [7], a priming line ball valve [8], check valve [3], a restrictor [4] and a pressure reducing pilot [9].

Under fire conditions, the hydrant valve is actuated manually by:

OCV HY: The 3-way ball valve is manually opened.

OCV HY\PR1: The pressure reducing pilot's adjustment bolt is tightened using a wrench and set to the required downstream pressure.

When actuated the hydrant valve opens instantly. When OCV HY\PR1 is actuated, the hydrant valve opens, regulating a steady preset downstream pressure regardless of upstream pressure or flow rate fluctuations.

OCV HY

Standby Position

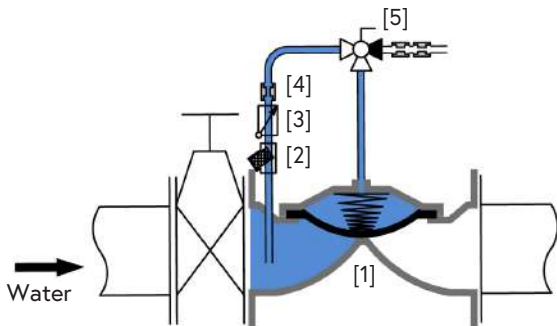

Manually Actuated

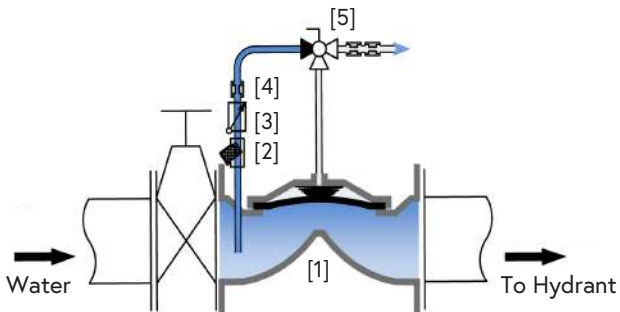

OCV HY\PR1

Standby Position

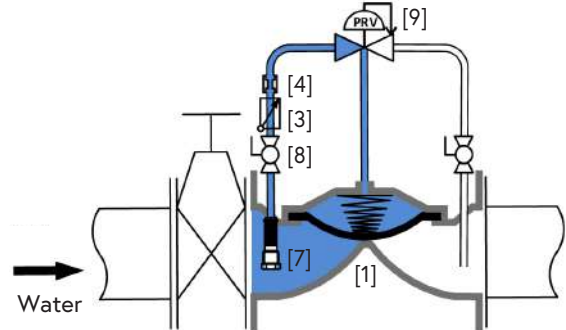

Manually Actuated & Pressure Reducing

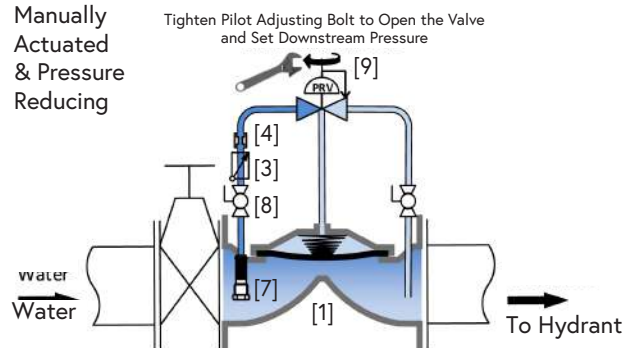

Resetting, maintenance, and periodic testing instructions must be followed as described in detail in the applicable OCV IOM (Installation, Operation & Maintenance) Manual.

Components & Typical Materials

The OCV HY & HY\PR1 consists of the following components, arranged as shown on the schematic diagram below.

ID	Part	Standard Material	POG (1) Applications
1	Valve Body	See OCV S100 Engineering Data (2)	
2	Check Valve	Brass	Stainless Steel 316
3	3-Way Ball Valve	Brass	Stainless Steel 316
4	Inline Strainer	Brass, Stainless Steel Screen	Stainless Steel 316
5	Pressure Gauge	Brass	Stainless Steel 316
6	Pressure Reducing Pilot	Brass	Stainless Steel 316
7	On/Off Selector Ball Valve	Brass	Stainless Steel 316

(1) Petrochemical, Oil & Gas

(2) Refer to materials selection guidelines, Engineering Data - Materials: Ductile Iron A-536 65-45-12; Cast Steel A-216 WCB; Cast Steel A-352 LCB; Austenitic Stainless Steel A-351/CF8M; Super Duplex 2507; Nickel-Aluminum-Bronze B-148 UNS C95800

HY

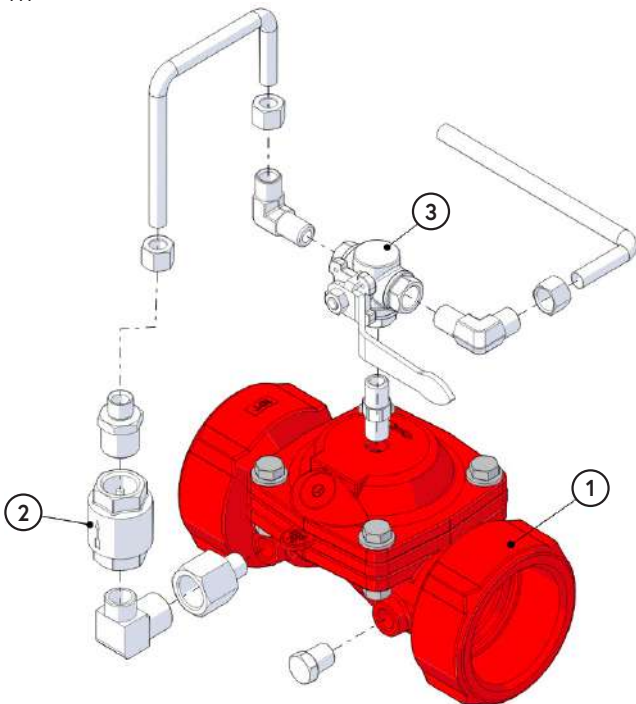

HY\PR1

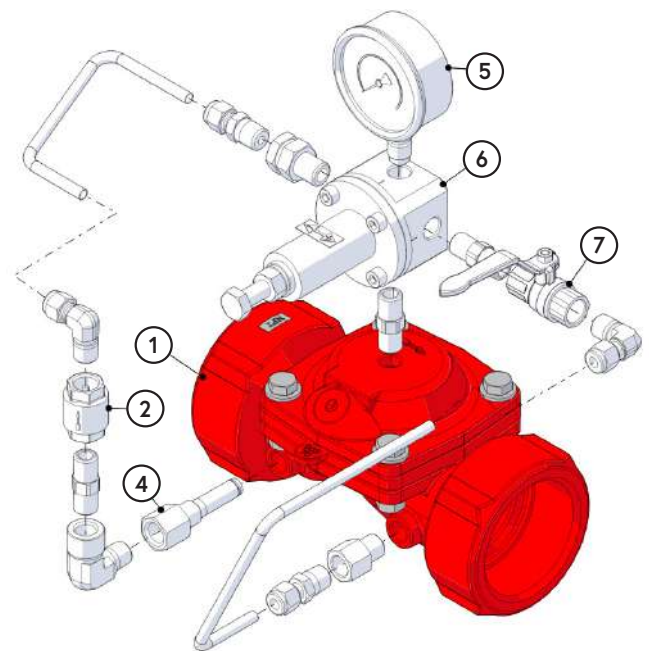

General Arrangement & Dimensions

Standard Sizes				
DIM	2"	2 1/2"	3"	4" (Flanged)
A	7 3/8	8 5/8	12 3/8	12
B	2	3	3 1/8	4
C	8 5/16	8 5/16	8 3/8	10 3/16
D	2 3/16	2 3/16	2 5/16	2 3/16
E	5 1/8	5 1/8	5 5/16	5 1/8

Approximate dimensions for OCV 44 HY\PR1.

Metric Sizes				
DIM	DN50	DN65	DN80	DN100 (Flanged)
A	188	219	316	305
B	50	65	80	100
C	210	212	214	260
D	56	56	59	56
E	130	130	136	130

Approximate dimensions for OCV 44 HY\PR1.

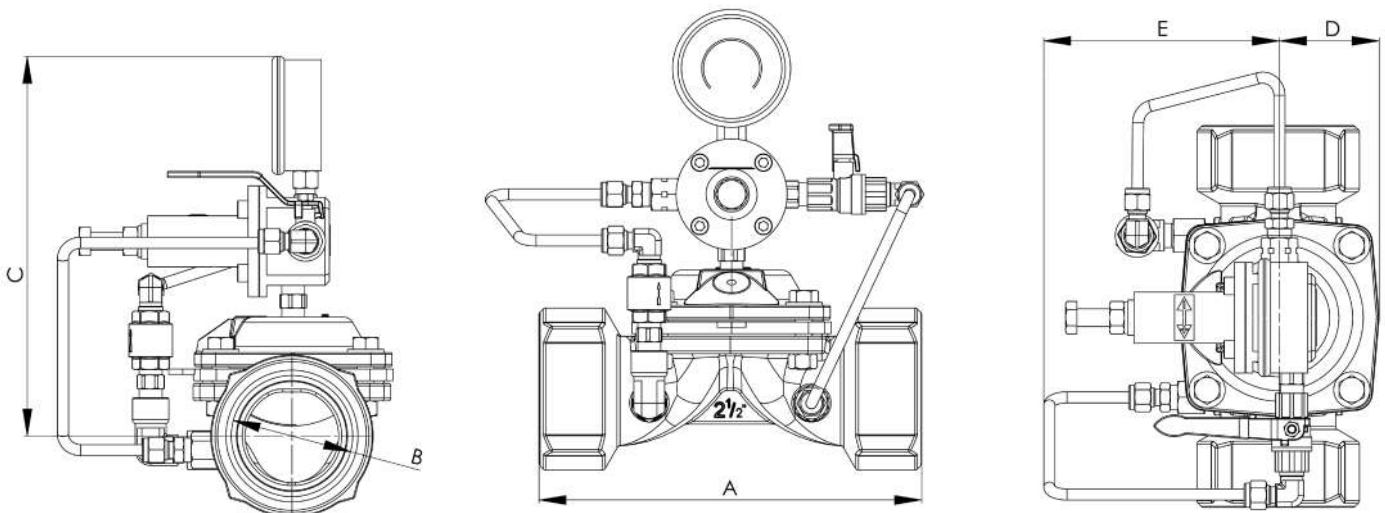

 **Typical Installation**

The typical installation of the OCV 44 HY\PR1 is as shown:



Technical Data

Temperature (Elastomers)	
Media	up to 85°C = 185°F
Elastomers	suitable for extreme climates (available upon request)
Sizes	
Straight Flow	Sizes: 2" - 24"
Lloyd's Type Approved Size	Model 68 (Flanged): 2" - 10" Model 77 (Flanged): 2" - 24" Model 44 (Threaded): 1" - 3"
Pressure Rating (ANSI at 100°F)	
250psi for Class 150#	Models 44 & 77: up to 16 bar / 230psi
375psi for Class 300#	Model 68: up to 25 bar / 375psi
End Connections	
Flanged	ISO-PN16 & ISO-PN25
	ANSI B16.42 & B16.5 Class 150# & 300#
	Additional options available upon request
Grooved	Sizes: 2"- 8"
Threaded	Sizes: 1"- 3"

Body & Cover Material	
Ductile Iron	Stainless Steel
Cast Steel	NAB
Trim Material	
Bronze/Brass - Copper	
Stainless Steel	
Monel	
Optional Components	
Upstream Drain Valve	
Pressure Switch	
Limit Proximity Switch	
Items to Specify	
Electrical features other than standard (24VDC, IP65/NEMA4)	
If explosion proof accessories are required such as solenoids, pressure switches, etc., please define classification	
Control trim material other than standard	
Required standards, certifications and approvals	

Engineering Specifications

The hydrant valve shall be hydraulically operated, direct elastomeric diaphragm-seal, single chamber weir type. The valve shall consist of three major components: the body, the cover and the diaphragm assembly. The diaphragm assembly shall be the only moving part. The diaphragm forms a sealed control chamber in the upper portion of the valve, separating operating pressure from line pressure. Packing glands, stuffing boxes and dynamic o-ring seals are not permitted and there shall not be shafts, discs, bearings or pistons operating the valve. No hourglass shaped disc retainers shall be permitted, and no V-type, U-type or other slotted type disc guides shall be used. The valve shall contain a nylon reinforced rubber diaphragm, elastic & resilient through its entire surface without vulcanized radial seals and/or

reinforcements. The diaphragm assembly shall not be guided by any shafts or bearings and shall not be in close contact with other valve parts except for its sealing surface. The hydrant valve shall be fully trimmed, hydrostatically and operationally tested at the factory. Maintenance, disassembly and reassembly of all the valve's components shall be made possible on-site and in-line, without the need to remove the valve from the line. Main valve body and bonnet standard material shall be ductile Iron or cast steel. Main valve body and bonnet surfaces shall include a fire red epoxy coating. Other materials and coatings available upon request. The hydrant valve shall be an OCV Series 100 HY or HY\PR1, Lloyd's Type Approved, as manufactured by OCV, an Aquestia Ltd. brand, Tulsa, OK, USA.