

Deluge Valves



General representation



Fire
Protection

Hydraulically Actuated Deluge Valve

Description

Hydraulically controlled deluge/pre-action valve, actuated by the pipeline pressure. The valve is closed in its normal, set position and opens when the hydraulic pressure drops in a pressurized pilot line, limited to 7m above the valve (for higher pilot lines, see OCV DE\HRV model sheet). An emergency manual release valve is fitted as standard. Also available with manual reset: DE\HM-MR.

Certification & Compliance

Lloyd's Register Approval



ANSI FCI 70-2 Class VI seat leakage class

Features & Benefits

- High pressure, high flow deluge systems
- Automatic or local manual emergency actuation
- Hazardous, flammable & explosion classified area fire suppression
- Superior design featuring exceptionally low pressure losses at high flow rates
- Low lifelong maintenance costs due to straightforward design
- Applicable for fresh or brackish water, seawater & foam
- Out of box fully assembled & tested valves
- Factory trimmed for vertical & horizontal installations without modification
- Extensive valve & trim materials selection and corrosion protection coating

Typical Applications

Automatic or Manual Actuated Fire Suppression Systems

Petrochemical, Oil & Gas Installations

Tunnels

Power Generation, Transformer & Transmission Plants



Flammable Storage

Hangers & Airport Terminals

Onshore/Offshore

Mining



Operation

The basic control valve [1] used in this deluge system is a direct sealing elastomeric diaphragm, hydraulically operated control valve engineered specifically for fire protection systems.

In the standby position, the deluge valve is held closed by the upstream water pressure, trapped in the valve's control chamber. The water pressure enters the control chamber through the priming line ball valve [2], a Y-Type strainer [3], a check valve [4] and a T-restrictor [5].

Under fire conditions, one (or more) of the automatic sprinklers on the wet pilot line burst. Water is drained from the deluge valve's control chamber through the burst sprinklers. The deluge valve opens instantly and allows water to flow into the pipeline and through the open sprinklers over the protected area.

Manual emergency actuation is enabled by opening the emergency manual activation valve [6]. The deluge valve opens instantly and allows water to flow into the pipeline and through the open sprinklers over the protected area.

Standby Position

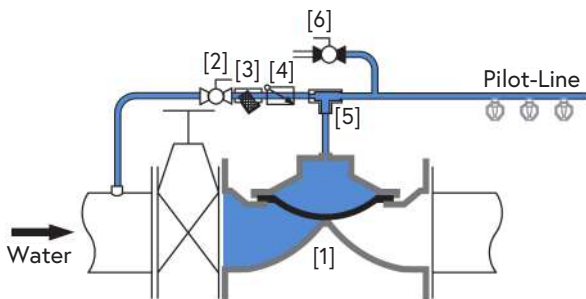

Electrically Actuated

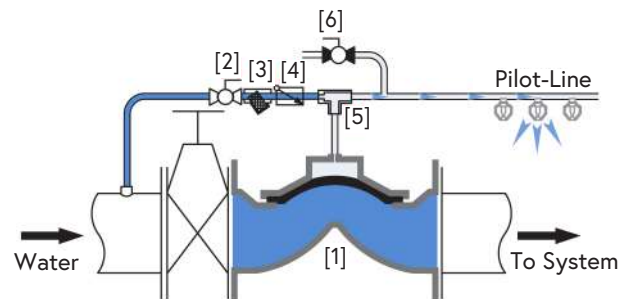

Manually Actuated

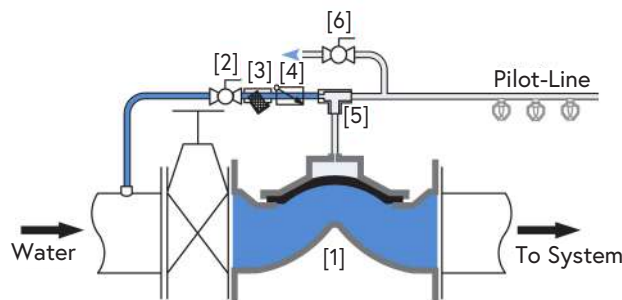

Resetting, maintenance, and periodic testing instructions must be followed as described in detail in the applicable OCV IOM (Installation, Operation & Maintenance) Manual.

 **Typical Installation**

The typical installation of the OCV 77 DE\HM is as shown:

- 1 Hydraulically Actuated Deluge Valve
- 2 Wet Pilot Line

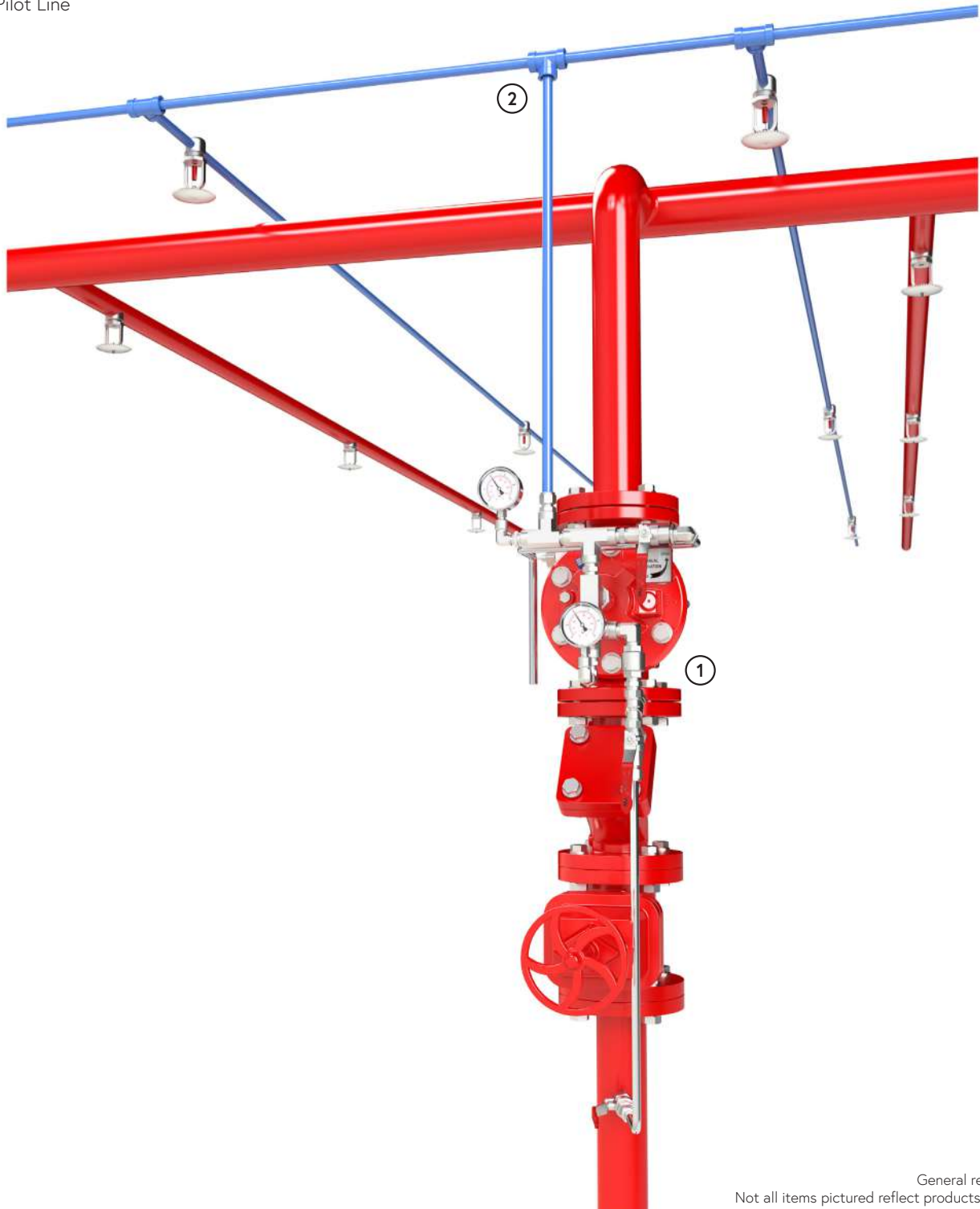

General representation.
Not all items pictured reflect products sold by OCV.

Technical Data

Temperature (Elastomers)	
Media	up to 80°C = 176°F
Elastomers	suitable for extreme climates (available upon request)
Sizes	
Lloyd's Type Approved	2" - 24"
Pressure Rating (ANSI at 100°F)	
230psi / 16 bars	
End Connections	
Flanged	ISO-PN16
	ANSI B16.42 & B16.5 Class 150#
	Additional options available upon request
Grooved	Sizes: 2"-6"

Body & Cover Material	
Ductile Iron	Stainless Steel
Cast Steel	NAB
Trim Material	
Bronze/Brass - Copper	
Stainless Steel	
Monel	
Optional Components	
Position Indicator	
Alarm Test Trim	
Upstream Drain Valve	
Pressure Switch	
Limit/Proximity Switch	
Items to Specify	
Electrical features other than standard (24VDC, IP65/NEMA4)	
If explosion proof accessories are required such as solenoids, pressure switches, etc., please define classification	
Control trim material other than standard	
Required standards, certifications and approvals	

Engineering Specifications

The deluge valve shall be hydraulically operated, direct elastomeric diaphragm-seal, single chamber weir type. The valve shall consist of three major components: the body, the cover and the diaphragm assembly. The diaphragm assembly shall be the only moving part. The diaphragm forms a sealed control chamber in the upper portion of the valve, separating operating pressure from line pressure. Packing glands, stuffing boxes and dynamic o-ring seals are not permitted and there shall not be shafts, discs, bearings or pistons operating the valve. No hourglass shaped disc retainers shall be permitted, and no V-type, U-type or other slotted type disc guides shall be used. The valve shall contain a nylon reinforced rubber diaphragm, elastic & resilient through its entire surface without vulcanized radial seals

and/or reinforcements. The diaphragm assembly shall not be guided by any shafts or bearings and shall not be in close contact with other valve parts except for its sealing surface. The deluge valve shall be fully trimmed, hydrostatically and operationally tested at the factory. Maintenance, disassembly and reassembly of all the valve's components shall be made possible on-site and in-line, without the need to remove the valve from the line. Main valve body and bonnet standard material shall be ductile iron or cast steel. Main valve body and bonnet surfaces shall include a fire red epoxy coating. Other materials and coatings available upon request. The deluge valve shall be a OCV 77 DE\HM, Lloyd's Type Approved, as manufactured by OCV, an Aquestia Ltd. brand, Tulsa, OK, USA.