

Deluge Valves



General representation



Fire Protection

Hydraulically Actuated, Manual Reset Deluge Valve

 Description

Hydraulically controlled deluge/pre-action valve, actuated by the pipeline pressure. The valve is closed in its normal, set position and opens when the hydraulic pressure drops in a pressurized pilot line, limited to 7m above the valve (for higher pilot lines, see OCV 68 DE\HRV-MR model sheet). The valve must be manually reset following automatic actuation. An emergency manual release valve is fitted as standard.

 Certification & Compliance

UL Listed under VLFT category



ABS Type Approval



Lloyd's Register Approval



ANSI FCI 70-2 Class VI seat leakage class

Fire tested to EN ISO 6182-5:2006 (2"-6" only)

 Typical Applications

Automatic or Manual Actuated Fire Suppression Systems

Petrochemical, Oil & Gas Installations

Tunnels

Power Generation, Transformer & Transmission Plants

 Features & Benefits

- High pressure (PN25/375psi), high flow deluge systems
- Automatic or local manual emergency actuation
- Hazardous, flammable & explosion classified area fire suppression
- Superior design featuring exceptionally low pressure losses at high flow rates
- Low lifelong maintenance costs due to straightforward design
- Applicable for fresh or brackish water, seawater & foam
- Out of box fully assembled & tested valves
- Factory trimmed for vertical & horizontal installations without modification
- Extensive valve & trim materials selection and corrosion protection coating

Flammable Storage

Hangers & Airport Terminals

Onshore/Offshore

Mining



Operation

The basic control valve [1] used in this deluge system is a direct sealing elastomeric diaphragm, hydraulically operated control valve engineered specifically for fire protection systems.

In the standby position, the deluge valve is held closed by the upstream water pressure, trapped in the valve's control chamber. The water pressure enters the control chamber through the priming line ball valve [2], a Y-Type strainer [3], a check valve [4] and a DMR (Manual Reset Latching Device) [5].

Under fire conditions, one (or more) of the automatic sprinklers on the wet pilot line burst. Water is drained from the deluge valve's control chamber through the burst sprinklers. The deluge valve opens instantly and allows water to flow into the pipeline and through the open sprinklers over the protected area.

Manual emergency actuation is enabled by opening the emergency manual activation valve [6]. The deluge valve opens instantly and allows water to flow into the pipeline and through the open sprinklers over the protected area.

When the valve trips open, the DMR isolates the control chamber from the upstream pressure source. Reconnecting the upstream pressure to enable the deluge valve to close can only be achieved by pressing the DMR's knob.

Standby Position

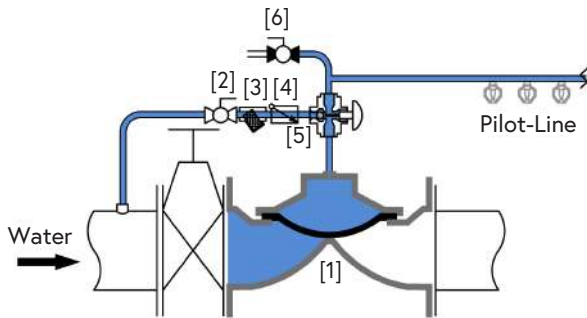

Hydraulically Actuated

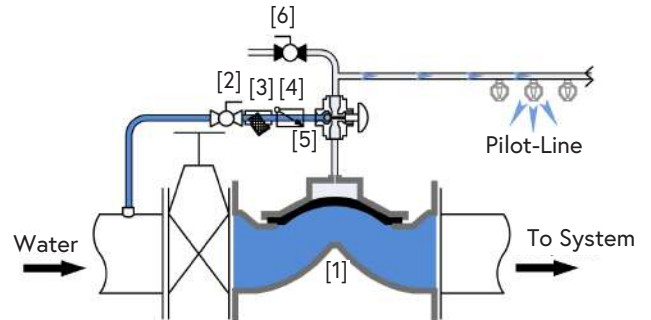

Manually Actuated

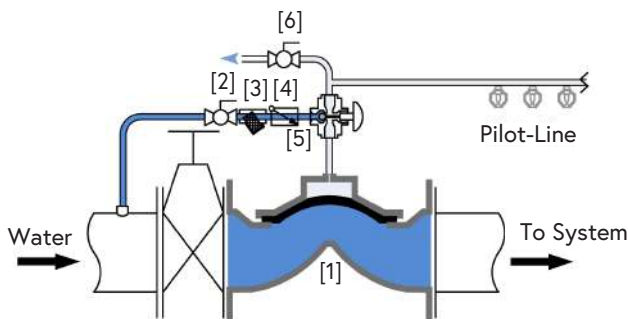

Reset To Close

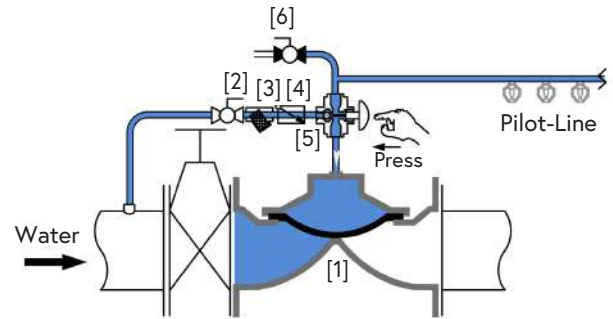

Resetting, maintenance, and periodic testing instructions must be followed as described in detail in the applicable OCV IOM (Installation, Operation & Maintenance) Manual.

Components & Typical Materials

The OCV 68 DE\HM-MR consists of the following components, arranged as shown on the schematic diagram below.

| ID | Part | Standard Material | POG (1) Applications |
|----|------------------------------------|-----------------------------------|----------------------|
| 1 | Valve Body | See OCV S100 Engineering Data (2) | |
| 2 | Ball Valve | Bronze, Stainless Steel Ball | Stainless Steel 316 |
| 3 | Y-Type Strainer | Bronze, Stainless Steel Screen | Stainless Steel 316 |
| 4 | Check Valve | Bronze | Stainless Steel 316 |
| 5 | DMR (Manual Reset Latching Device) | Brass | Stainless Steel 316 |
| 6 | Manual Emergency Valve | Bronze | Stainless Steel 316 |
| 7 | Drip Valve | Brass | Stainless Steel 316 |
| 8 | Pressure Gauge (optional) | Stainless Steel | Stainless Steel 316 |

(1) Petrochemical, Oil & Gas

(2) Refer to materials selection guidelines, Engineering Data - Materials: Ductile Iron A-536 65-45-12; Cast Steel A-216 WCB; Cast Steel A-352 LCB; Austenitic Stainless Steel A-351/CF8M; Super Duplex 2507; Nickel-Aluminum-Bronze B-148 UNS C95800

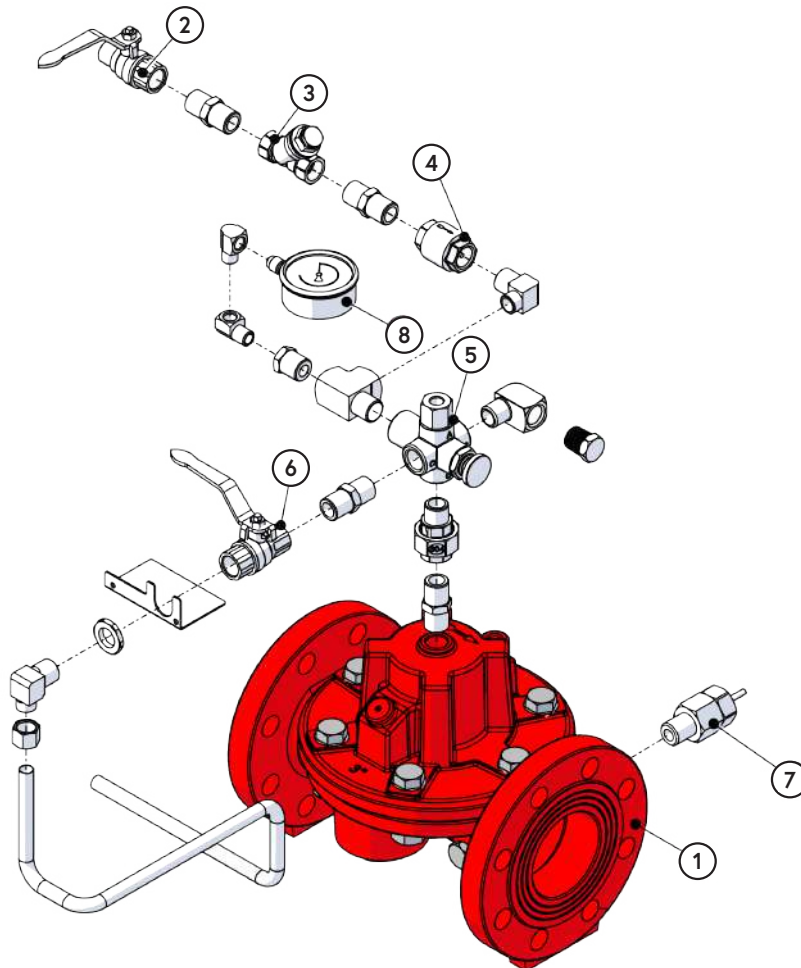

General Arrangement & Dimensions

| Standard Sizes | | | | | | | |
|-------------------------------|---------|---------|---------|---------|---------|---------|---------|
| DIM | 2" | 2 1/2" | 3" | 4" | 6" | 8" | 10" |
| A | 9 5/8 | 9 3/16 | 12 3/16 | 14 | 17 3/16 | 20 7/8 | 25 |
| A _G ⁽¹⁾ | 9 5/8 | 10 | 13 3/16 | 15 | 17 5/16 | 21 7/8 | -- |
| B | 6 5/8 | 7 3/8 | 7 7/8 | 9 3/8 | 12 1/8 | 14 3/16 | 16 7/8 |
| C | 4 11/16 | 4 11/16 | 6 | 6 5/8 | 7 11/16 | 9 5/16 | 11 3/16 |
| D | 5 11/16 | 5 11/16 | 5 11/16 | 5 11/16 | 6 3/8 | 7 7/8 | 9 7/8 |
| E | 8 11/16 | 8 11/16 | 11 3/8 | 11 1/8 | 14 3/8 | 15 3/16 | 16 1/8 |
| F | 10 3/8 | 10 3/8 | 10 3/8 | 10 3/8 | 10 3/8 | 10 3/8 | 12 1/2 |

Approximate Dimensions. ⁽¹⁾ Grooved model length.

| Metric Sizes | | | | | | | |
|-------------------------------|------|------|------|-------|-------|-------|-------|
| DIM | DN50 | DN65 | DN80 | DN100 | DN150 | DN200 | DN250 |
| A | 243 | 233 | 310 | 356 | 436 | 530 | 635 |
| A _G ⁽¹⁾ | 243 | 253 | 336 | 380 | 440 | 556 | -- |
| B | 168 | 185 | 200 | 238 | 306 | 360 | 430 |
| C | 120 | 120 | 153 | 167 | 196 | 236 | 285 |
| D | 145 | 145 | 145 | 145 | 160 | 200 | 249 |
| E | 221 | 221 | 287 | 283 | 366 | 386 | 409 |
| F | 262 | 262 | 262 | 262 | 262 | 265 | 317 |

Approximate Dimensions. ⁽¹⁾ Grooved model length.

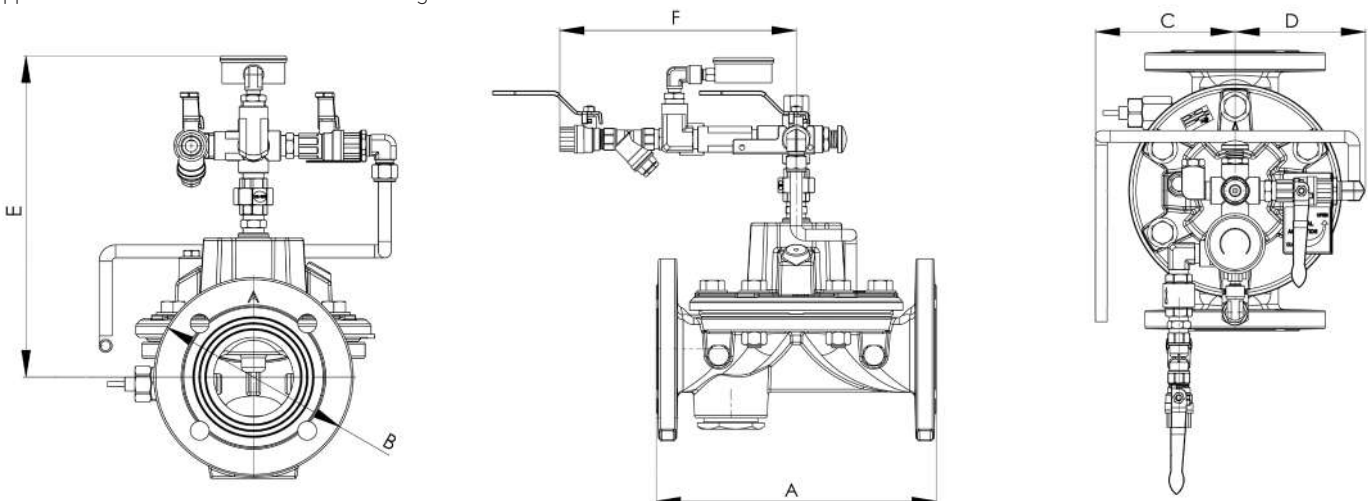

 Typical Installation

The typical installation of the OCV 68 DE\HM-MR is as shown:

- 1 Hydraulically Actuated, Manual Reset Deluge Valve
- 2 Wet Pilot Line
- 3 DMR (Manual Reset Latching Device)

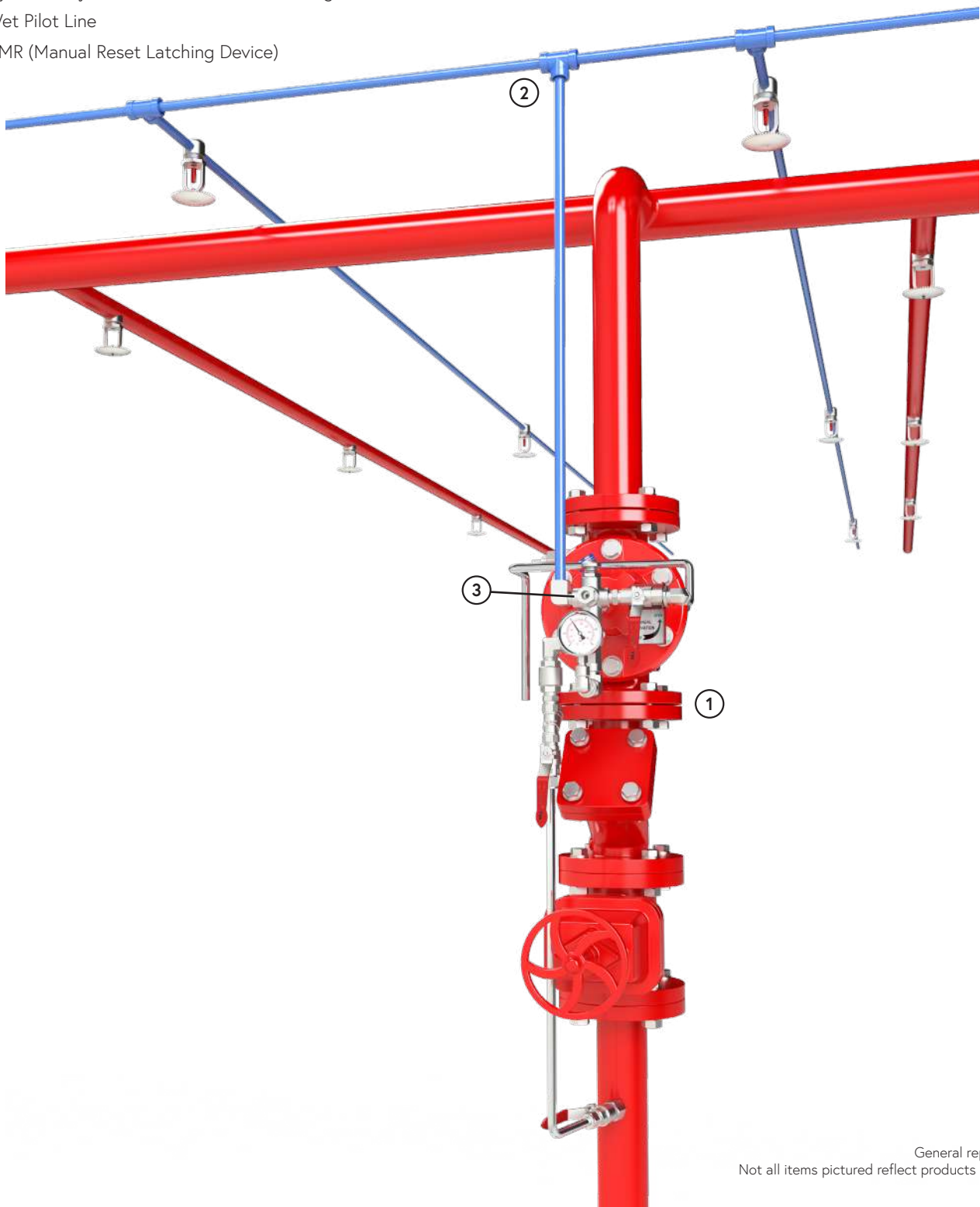

General representation.
Not all items pictured reflect products sold by OCV.

Technical Data

| Temperature (Elastomers) | |
|---------------------------------|--|
| Media | up to 80°C = 176°F |
| Elastomers | suitable for extreme climates (available upon request) |
| Sizes | |
| UL Listed Model 68 | 2" - 10" |
| Straight Flow | 2" - 24" |
| Pressure Rating (ANSI at 100°F) | |
| 250psi for Class 150# | |
| 375psi for Class 300# | |
| End Connections | |
| Flanged | ISO-PN16 & ISO-PN25 |
| | ANSI B16.42 & B16.5 Class 150# & 300# |
| | Additional options available upon request |
| Grooved | Sizes: 2"-8" |

| Body & Cover Material | |
|--|-----------------|
| Ductile Iron | Stainless Steel |
| Cast Steel | NAB |
| Trim Material | |
| Bronze/Brass - Copper | |
| Stainless Steel | |
| Monel | |
| Optional Components | |
| Position Indicator | |
| Alarm Test Trim | |
| Upstream Drain Valve | |
| Pressure Switch | |
| Limit/Proximity Switch | |
| Spring | |
| Items to Specify | |
| Electrical features other than standard (24VDC, IP65/NEMA4) | |
| If explosion proof accessories are required such as solenoids, pressure switches, etc., please define classification | |
| Control trim material other than standard | |
| Required standards, certifications and approvals | |

Engineering Specifications

The deluge valve shall be hydraulically operated, direct elastomeric diaphragm-seal, single chamber weir type. The valve shall consist of three major components: the body, the cover and the diaphragm assembly. The diaphragm assembly shall be the only moving part. The diaphragm forms a sealed control chamber in the upper portion of the valve, separating operating pressure from line pressure. Packing glands, stuffing boxes and dynamic O-ring seals are not permitted and there shall not be shafts, discs, bearings or pistons operating the valve. No hourglass shaped disc retainers shall be permitted, and no V-type, U-type or other slotted type disc guides shall be used. The valve shall contain a nylon reinforced rubber diaphragm, elastic & resilient through its entire surface without vulcanized radial seals

and/or reinforcements. The diaphragm assembly shall not be guided by any shafts or bearings and shall not be in close contact with other valve parts except for its sealing surface. The deluge valve shall be fully trimmed, hydrostatically and operationally tested at the factory. Maintenance, disassembly and reassembly of all the valve's components shall be made possible on-site and in-line, without the need to remove the valve from the line. Main valve body and bonnet standard material shall be ductile iron or cast steel. Main valve body and bonnet surfaces shall include a fire red epoxy coating. Other materials and coatings available upon request. The deluge valve shall be an OCV 68 DE\HM-MR, UL Listed under VLFT category, as manufactured by OCV, an Aquestia Ltd. brand, Tulsa, OK, USA.