

Deluge Pressure Reducing Valves



General representation



Fire
Protection

Electrically or Hydraulically Actuated, Anti-Columning, Pressure Reducing, Manual Reset Deluge Valve

Description

Electrically or hydraulically, pilot controlled deluge/pre-action valve, actuated by the pipeline pressure. The valve is closed in its normal, set position and opens when the hydraulic pressure drops in a water pressurized pilot line, releasing a hydraulic relay, or by an electric command. When tripped, the valve regulates to a steady, preset downstream pressure, regardless of upstream pressure or flow rate fluctuations. The valve must be manually reset following automatic actuation. An emergency manual release valve is fitted as standard.

Certification & Compliance

UL Listed under VLFT category



ABS Type Approval



Lloyd's Register Approval



ANSI FCI 70-2 Class VI seat leakage class

Fire tested to EN ISO 6182-5:2006 (2"-6" only)

Typical Applications

Automatic or Manual Actuated Fire Suppression Systems

Petrochemical, Oil & Gas Installations

Tunnels

Power Generation, Transformer & Transmission Plants



Features & Benefits

- High pressure (PN25/375psi), high flow deluge systems
- Automatic or manual emergency actuation
- Hazardous, flammable & explosion classified area fire suppression
- Superior design featuring exceptionally low pressure losses at high flow rates
- Low lifelong maintenance costs due to straightforward design
- Applicable for water, seawater & foam
- Out of box fully assembled & tested valves
- Factory trimmed for vertical & horizontal installations without modification
- Extensive valve & trim materials selection and corrosion protection coating

Flammable Storage

Hangers & Airport Terminals

Onshore/Offshore

Mining



Deluge Pressure Reducing Valves

Operation

The basic control valve [1] used in this deluge system is a direct-sealing elastomeric diaphragm, hydraulically operated control valve engineered specifically for fire protection systems.

In the standby position, the deluge valve is held closed by the upstream water pressure, trapped in the valve's control chamber. The water pressure enters the control chamber through the priming line ball valve [2], a Y-type strainer [3], a check valve [4] and a T-restrictor [5].

Under fire conditions, the deluge valve opens automatically under any of the following circumstances:

1. A fire alarm control panel (F&G panel) energizes the 2/2-way N.C. solenoid [10] (or de-energizes the coil of a continuously energized ED 100% normally open solenoid for SIL 3-4 rated systems).
2. The pressure in the wet (hydraulically pressurized) pilot line drops, following bursting of one (or more) of the automatic sprinklers.

When this happens, the pressure in the relay valve [9] drops, causing it to open and allowing the water to begin to drain from the deluge valve's control chamber through the pressure reducing pilot [11]. The deluge valve opens instantly, regulating to a steady, preset downstream pressure, regardless of upstream pressure or flow rate fluctuations. This allows water to flow into the pipeline and through the open sprinklers over the protected area.

Manual emergency actuation is enabled by opening the emergency manual activation valve [6]. When connected through the pressure reducing pilot (upon request), manual actuation causes the deluge valve to regulate the downstream pressure regardless of upstream pressure or flow rate fluctuations. If unspecified, the manual activation valve drains the water to the atmosphere, allowing the deluge valve to open fully. When actuated, the deluge valve opens instantly and allows water to flow into the pipeline and through the open sprinklers over the protected area.

When the valve trips open, the DMR (manual reset latching device) [12] isolates the relay valve from the pressure source. Reconnecting the pressure source to enable the deluge valve to close can only be achieved by pressing the DMR's knob.

Standby Position

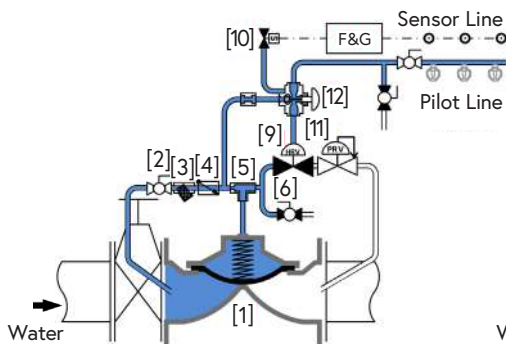

Electrically Actuated & Pressure Reducing

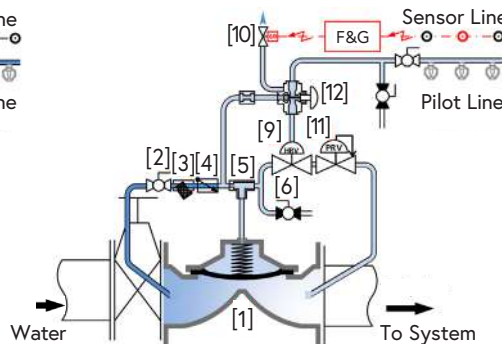

Hydraulically Actuated & Pressure Reducing

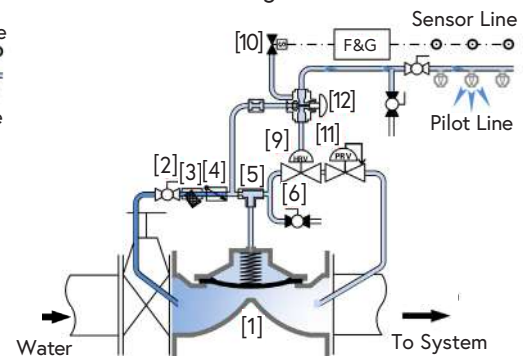

Manually Actuated & Pressure Reducing

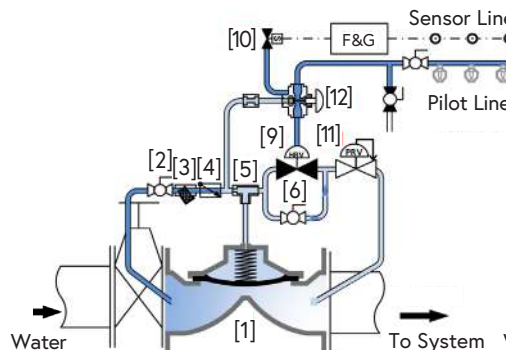

Manually Actuated (Standard)

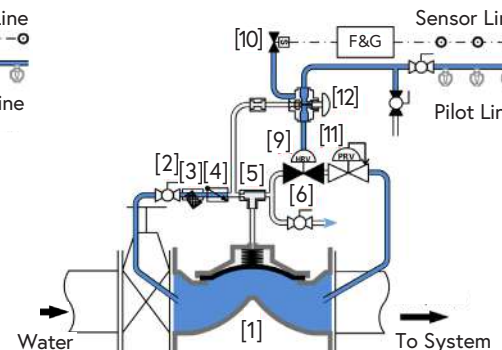

Reset To Close

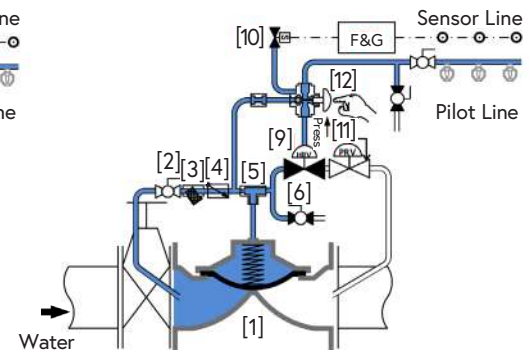

Resetting, maintenance, and periodic testing instructions must be followed as described in detail in the applicable OCV IOM (Installation, Operation & Maintenance) Manual.

Components & Typical Materials

The OCV 68 DE\EL\HRV\PR-MR consists of the following components, arranged as shown on the schematic diagram below.

| ID | Part | Standard Material | POG (1) Applications |
|----|------------------------------------|-----------------------------------|----------------------|
| 1 | Valve Body | See OCV S100 Engineering Data (2) | |
| 2 | Ball Valve | Bronze, Stainless Steel Ball | Stainless Steel 316 |
| 3 | Y-Type Strainer | Bronze, Stainless Steel Screen | Stainless Steel 316 |
| 4 | Check Valve | Bronze | Stainless Steel 316 |
| 5 | T-Restrictor | Brass | Stainless Steel 316 |
| 6 | Manual Emergency Valve | Bronze | Stainless Steel 316 |
| 7 | Drip Valve | Brass | Stainless Steel 316 |
| 8 | Pressure Gauge | Stainless Steel | Stainless Steel 316 |
| 9 | 66-2UL Relay | Brass | Stainless Steel 316 |
| 10 | 2/2 Way N.C. Solenoid (3) | Brass | Stainless Steel 316 |
| 11 | CXPR Pressure Reducing Pilot | Brass, Stainless Steel 316 Seat | Stainless Steel 316 |
| 12 | DMR (Manual Reset Latching Device) | Brass | Stainless Steel 316 |

(1) Petrochemical, Oil & Gas

(2) Refer to materials selection guidelines, Engineering Data - Materials: Ductile Iron A-536 65-45-12; Cast Steel A-216 WCB; Cast Steel A-352 LCB; Austenitic Stainless Steel A-351/CF8M; Super Duplex 2507; Nickel-Aluminum-Bronze B-148 UNS C95800

(3) Consult fac

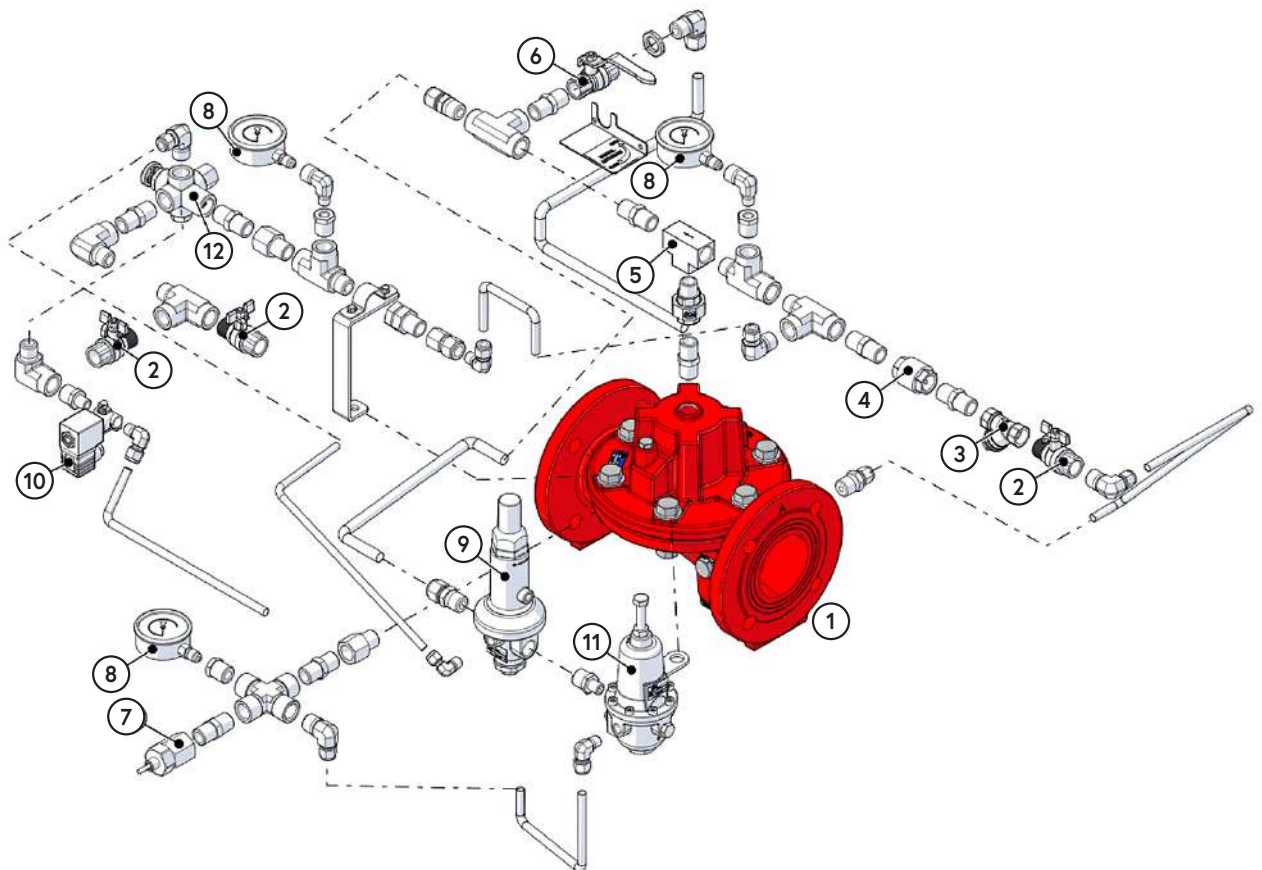

General Arrangement & Dimensions

| Standard Sizes | | | | | | | |
|-------------------------------|----------|----------|----------|----------|----------|----------|----------|
| DIM | 2" | 2 1/2" | 3" | 4" | 6" | 8" | 10" |
| A | 9 5/8 | 9 3/16 | 12 3/16 | 14 | 17 3/16 | 20 7/8 | 25 |
| A _G ⁽¹⁾ | 9 5/8 | 10 | 13 3/16 | 15 | 17 5/16 | 21 7/8 | -- |
| B | 14 13/16 | 14 13/16 | 14 13/16 | 14 13/16 | 14 13/16 | 14 13/16 | 14 13/16 |
| C | 10 11/16 | 10 11/16 | 10 11/16 | 10 11/16 | 10 11/16 | 10 11/16 | 12 1/2 |
| D | 10 3/8 | 10 3/8 | 10 7/8 | 11 5/16 | 12 5/8 | 13 5/16 | 14 5/16 |
| E | 6 11/16 | 6 11/16 | 7 3/16 | 7 5/8 | 8 7/8 | 9 5/8 | 10 5/8 |
| F | 3 5/16 | 3 5/16 | 4 1/8 | 4 11/16 | 5 7/8 | 7 1/8 | 8 1/2 |
| G | 10 5/8 | 10 5/8 | 12 13/16 | 12 13/16 | 16 1/8 | 18 5/8 | 19 1/2 |

Approximate Dimensions. ⁽¹⁾ Grooved model length.

| Metric Sizes | | | | | | | |
|-------------------------------|------|--------|------|-------|-------|-------|-------|
| DIM | DN50 | DN65 | DN80 | DN100 | DN150 | DN200 | DN250 |
| A | 243 | 233 | 310 | 356 | 436 | 530 | 635 |
| A _G ⁽¹⁾ | 243 | 253 | 336 | 380 | 440 | 556 | -- |
| B | 376 | 376 | 376 | 376 | 376 | 376 | 376 |
| C | 272 | 272 | 272 | 272 | 272 | 272 | 318 |
| D | 264 | 264 | 277 | 288 | 320 | 338 | 364 |
| E | 170 | 170 | 183 | 194 | 226 | 244 | 270 |
| F | 85 | 92 1/2 | 105 | 120 | 150 | 180 | 215 |
| G | 268 | 268 | 324 | 324 | 409 | 472 | 494 |

Approximate Dimensions. ⁽¹⁾ Grooved model length.

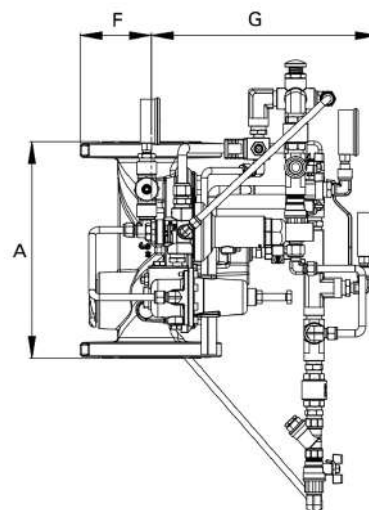
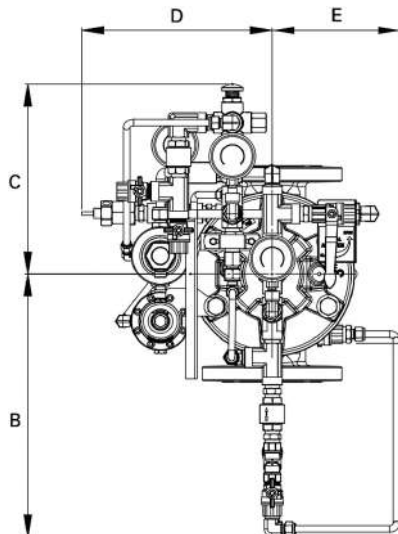

Typical Installation

The typical installation of the OCV 68 DE\EL\HRV\PR-MR is as shown:

- 1 Electrically or Hydraulically Actuated, Anti-Columning, Pressure Reducing, Manual Reset Deluge Valve
- 2 Wet Pilot Line
- 3 CXPR Pressure Reducing Pilot
- 4 DMR (Manual Reset Latching Device)
- 5 Fire Alarm Control Panel

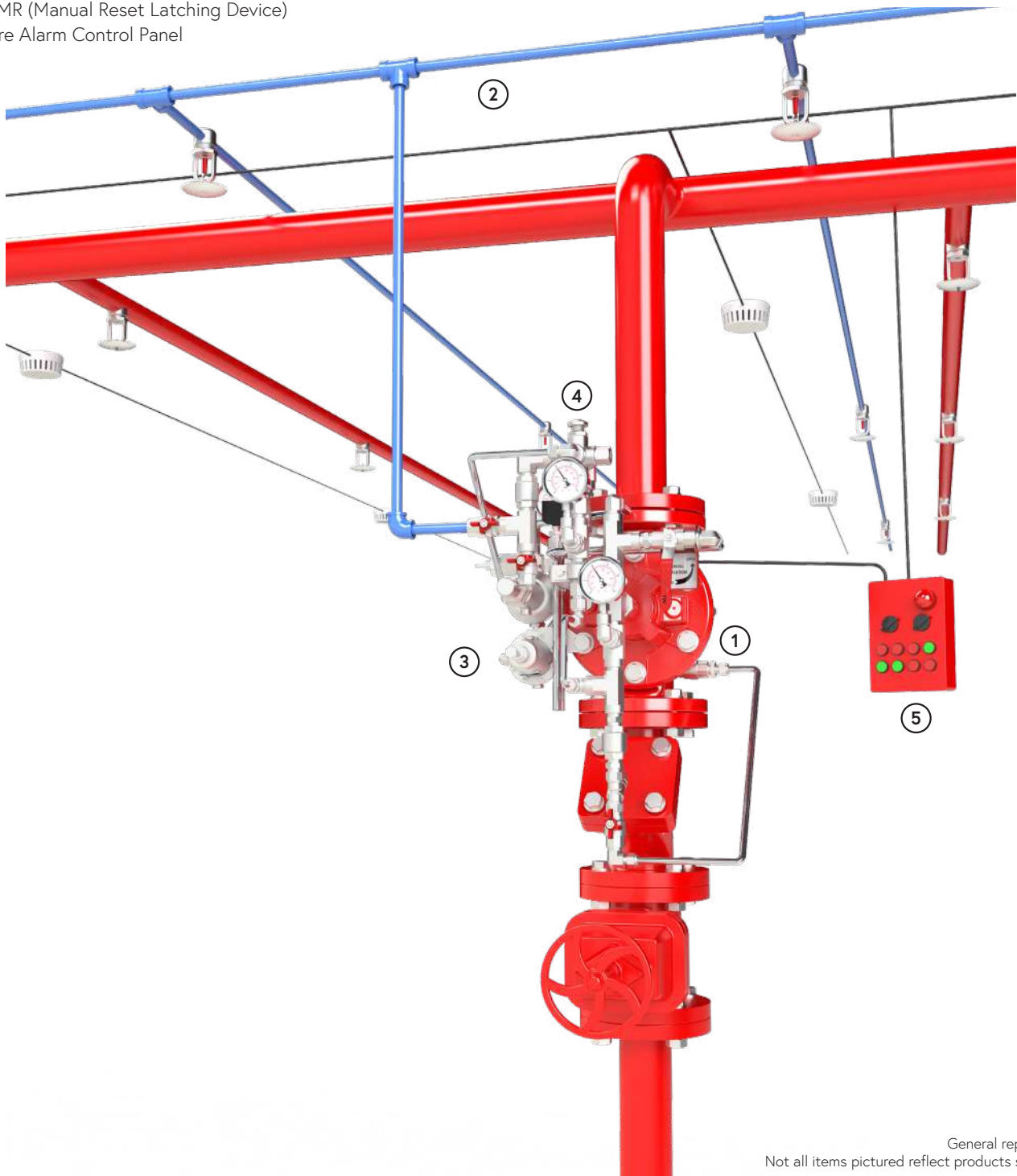

General representation.
Not all items pictured reflect products sold by OCV.

Technical Data

| Temperature (Elastomers) | |
|---------------------------------|--|
| Media | up to 80°C = 176°F |
| Elastomers | suitable for extreme climates (available upon request) |
| Sizes | |
| UL Listed Model 68 | 2" - 10" |
| Straight Flow | 2" - 24" |
| Pressure Rating (ANSI at 100°F) | |
| 250psi for Class 150# | |
| 375psi for Class 300# | |
| End Connections | |
| Flanged | ISO-PN16 & ISO-PN25 |
| | ANSI B16.42 & B16.5 Class 150# & 300# |
| | Additional options available upon request |
| Grooved | Sizes: 2"-8" |

| Body & Cover Material | |
|--|-----------------|
| Ductile Iron | Stainless Steel |
| Cast Steel | NAB |
| Trim Material | |
| Bronze/Brass - Copper | |
| Stainless Steel | |
| Monel | |
| Optional Components | |
| Position Indicator | |
| Alarm Test Trim | |
| Upstream Drain Valve | |
| Pressure Switch | |
| Limit/Proximity Switch | |
| Items to Specify | |
| Electrical features other than standard (24VDC, IP65/NEMA4) | |
| If explosion proof accessories are required such as solenoids, pressure switches, etc., please define classification | |
| Control trim material other than standard | |
| Required standards, certifications and approvals | |

Engineering Specifications

The deluge valve shall be hydraulically operated, direct elastomeric diaphragm-seal, single chamber weir type. The valve shall consist of three major components: the body, the cover and the diaphragm assembly. The diaphragm assembly shall be the only moving part. The diaphragm forms a sealed control chamber in the upper portion of the valve, separating operating pressure from line pressure. Packing glands, stuffing boxes and dynamic o-ring seals are not permitted and there shall not be shafts, discs, bearings or pistons operating the valve. No hourglass shaped disc retainers shall be permitted, and no V-type, U-type or other slotted type disc guides shall be used. The valve shall contain a nylon reinforced rubber diaphragm, elastic & resilient through its entire surface without vulcanized radial seals

and/or reinforcements. The diaphragm assembly shall not be guided by any shafts or bearings and shall not be in close contact with other valve parts except for its sealing surface. The deluge valve shall be fully trimmed, hydrostatically and operationally tested at the factory. Maintenance, disassembly and reassembly of all the valve's components shall be made possible on-site and in-line, without the need to remove the valve from the line. Main valve body and bonnet standard material shall be ductile iron or cast steel. Main valve body and bonnet surfaces shall include a fire red epoxy coating. Other materials and coatings available upon request. The deluge valve shall be an OCV 68 DE\EL\HRV\PR-MR, UL Listed under VLFT category, as manufactured by OCV, an Aquestia Ltd. brand, Tulsa, OK, USA.