

Local & Remote Monitor Systems



Fire Protection



Description

MO\M Manually Actuated Monitor Valve: The valve is closed in its normal, set position and opens when an activation selector valve is turned to the open position. It gradually closes drip tight when the selector valve is turned back to the closed position, reducing the risk of water hammer damage.

MO\RC Remote Hydraulic/Pneumatic Actuated Monitor Valve: The valve is closed in its normal, set position and opens when the activation ball valve is turned to the open position or when a remote activation ball valve is turned to the open position. It gradually closes drip tight when the selector valve is turned back to the closed position, reducing the risk of water hammer damage.

MO\EL Electrically Actuated Monitor Valve: The valve is closed in its normal, set position and opens when an activation ball valve is turned to the open position or when a solenoid valve is energized. It gradually closes drip tight when the ball valve is turned back to the closed position or the solenoid valve is de-energized, reducing the risk of water hammer damage.



Features & Benefits

- High pressure (PN25/375psi), high flow systems
- Automatic or manual emergency actuation
- Hazardous, flammable & explosion classified area fire suppression
- Superior design featuring exceptionally low pressure losses at high flow rates
- Low lifelong maintenance costs due to straightforward design
- Applicable for fresh or brackish water, seawater & foam
- Out of box fully assembled & tested valves
- Factory trimmed for vertical & horizontal installations without modification
- Extensive valve & trim materials selection and corrosion protection coating
- Optional low power electric actuation



Certification & Compliance

ABS Type Approval



Lloyd's Register Approval



ANSI FCI 70-2 Class VI seat leakage class

Fire tested to EN ISO 6182-5:2006 (OCV 68: 2"-6" only)



Typical Applications

Automatic or Manual Actuated Fire Suppression Systems



Petrochemical, Oil & Gas Installations



Power Generation, Transformer & Transmission Plants



Flammable Storage



Hangers & Airport Terminals



Onshore/Offshore



Operation

These hydraulically, pneumatically or electrically actuated monitor valves are designed for local, remote controlled and oscillating monitors. The basic control valve [1] used for these monitor systems is a direct sealing elastomeric diaphragm, hydraulically operated control valve engineered specifically for fire protection systems.

In the standby position, the monitor valve is held closed by the upstream water pressure, trapped in the valve's control chamber. The water pressure enters the control chamber through a Y-type strainer [2], a check valve [3], a restrictor [4] and a 3-way ball valve [5].

Under fire conditions, the monitor valves will open following these circumstances:

MO\M: The 3-way ball valve is manually opened.

MO\RC: A) A remote 2-way ball valve [6] or a local 3-way ball valve is manually opened.

B) With relay valve [8] - a remote 3-way ball valve or a local 3-way ball valve is manually opened.

MO\EL: A fire alarm control panel (F&G panel) energizes the 3/2-way N.O. solenoid [7] (or de-energizes the coil of a continuously energized ED 100% normally closed solenoid for SIL 3-4 rated systems).

When opened, water begins to drain from the monitor valve's control chamber. The valve opens instantly, allowing water to flow into the pipeline, through the monitor and over the protected area. Adding a relay valve (see Option B - MO\RC) allows remote hydraulic actuation even for long pipelines or changing topography.

A relay valve is also added for large diameter electrically actuated monitor valves (see Electrically Actuated - 6" and larger).

MO\M
Local Manual
Actuation

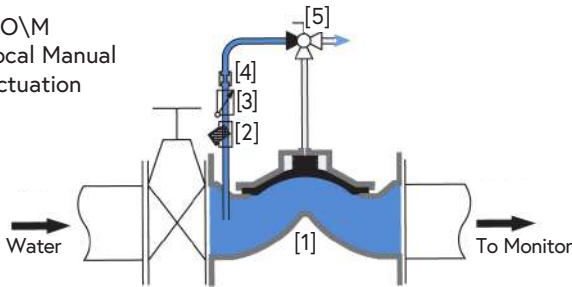

MO\RC
Remote
Hydraulic
Actuation

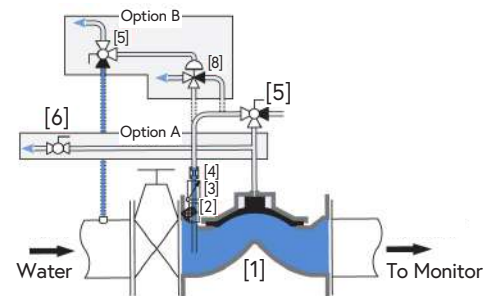

MO\RC
Local Manual
Actuation

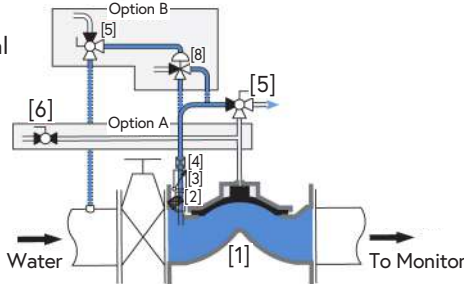

MO\EL
Electrical
Actuation
1 1/2" - 4"

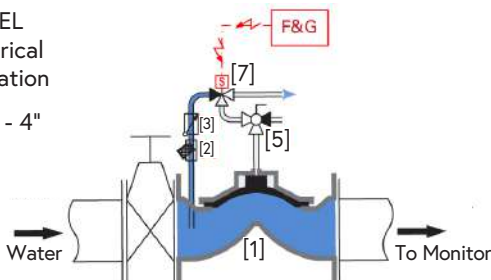

MO\EL
Electrical
Actuation
6" & larger

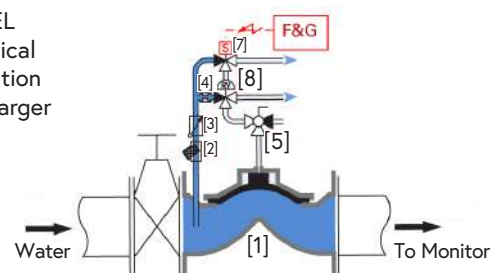

Resetting, maintenance, and periodic testing instructions must be followed as described in detail in the applicable OCV IOM (Installation, Operation & Maintenance) Manual.

Components & Typical Materials

The OCV 44, 68, 77 MO\M, MO\RC, MO\EL consists of the following components, arranged as shown on the schematic diagram below.

ID	Part	Standard Material	POG (1) Applications
1	Valve Body	See OCV S100 Engineering Data (2)	
2	Y-Type Strainer	Bronze, Stainless Steel Screen	Stainless Steel 316
3	Check Valve	Bronze	Stainless Steel 316
4	Restrictor	Brass	Stainless Steel 316
5	3-Way Ball Valve	Bronze	Stainless Steel 316
6	3/2 Way N.O. Solenoid (3)	Brass	Stainless Steel 316
7	66-213 Relay	Brass	Stainless Steel 316

(1) Petrochemical, Oil & Gas

(2) Refer to materials selection guidelines, Engineering Data - Materials: Ductile Iron A-536 65-45-12; Cast Steel A-216 WCB; Cast Steel A-352 LCB; Austenitic Stainless Steel A-351/CF8M; Super Duplex 2507; Nickel-Aluminum-Bronze B-148 UNS C95800

(3) Consult factory

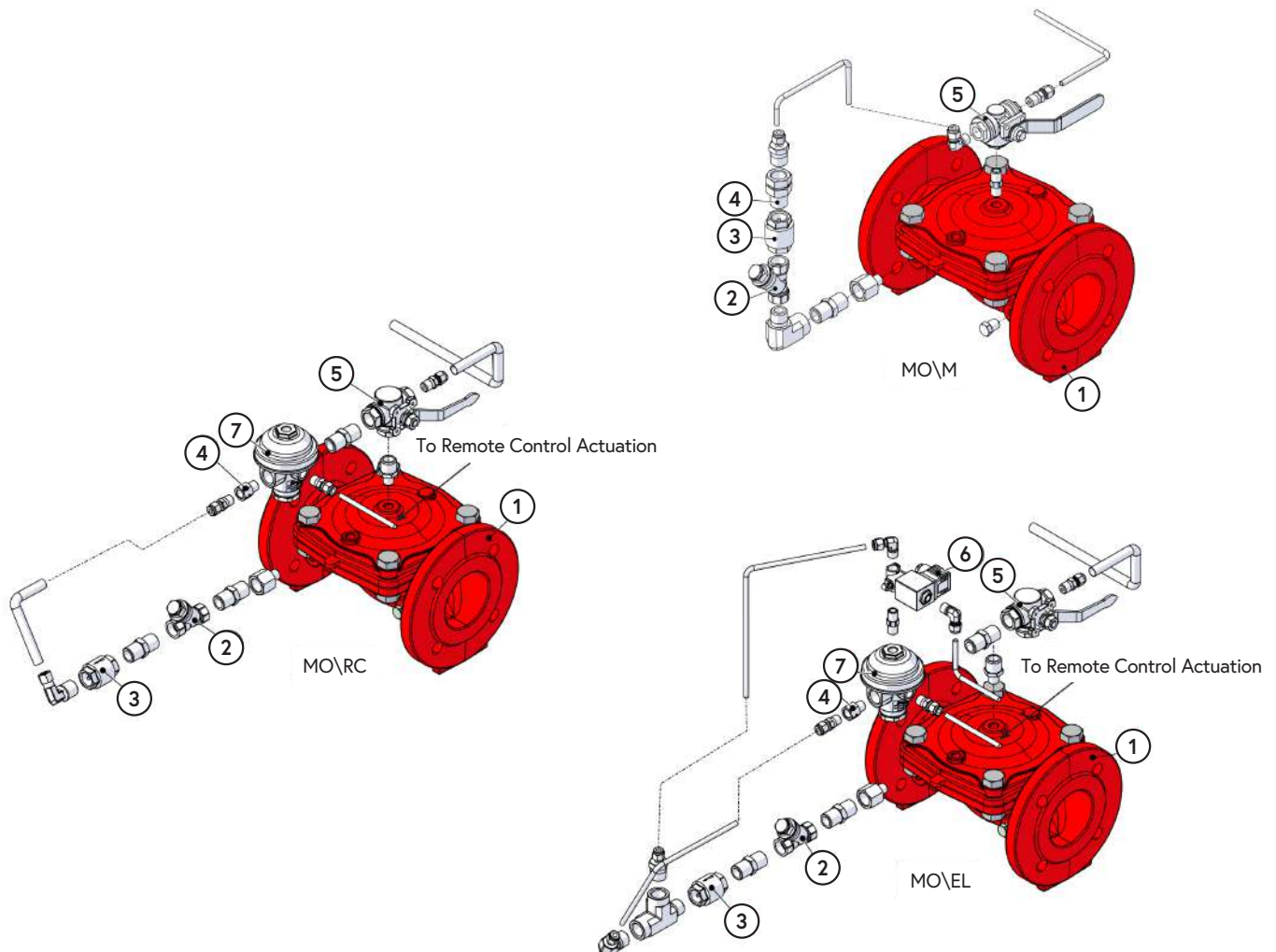

General Arrangement & Dimensions

Standard Sizes						
DIM	2"	3"	4"	6"	8"	10"
A	6 1/2	7 7/8	9 1/8	11	13 1/2	17 5/16
B	7 7/8	11 3/16	12	15 3/8	18 1/8	21 1/8
C	7 5/8	7 13/16	8 1/2	12 3/16	14	15 1/8
D	3 3/8	9 7/8	10 1/8	11 5/8	13 5/16	13 1/2
E	3 1/8	4 1/8	4 3/16	6	7 13/16	9 3/8

Approximate Dimensions OCV 77 MO\RC.

Metric Sizes						
DIM	DN50	DN80	DN100	DN150	DN200	DN250
A	166	200	230	280	342	440
B	200	285	305	390	460	535
C	192	197	216	309	355	383
D	86	252	256	294 1/2	338	343
E	80	105	106	153	197	240

Approximate Dimensions OCV 77 MO\RC.

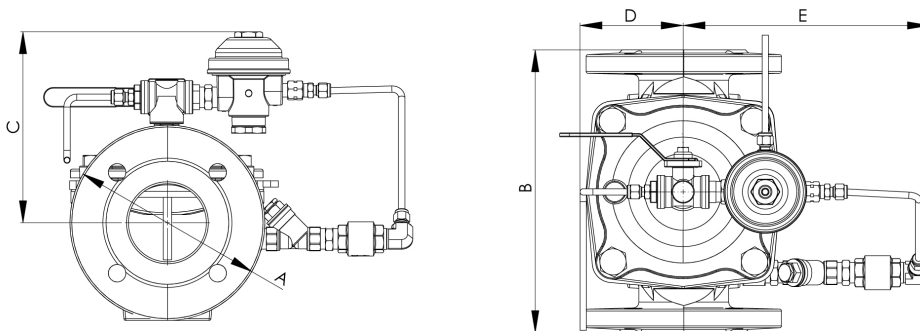

Traditional Monitor Valves
Difficult Mechanical Actuation

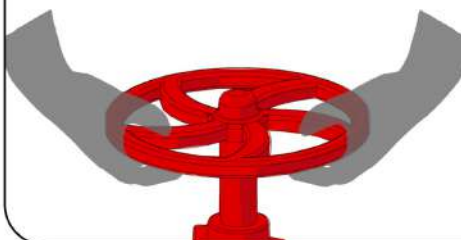

OCV Monitor Valves
Easy & Effortless Hydraulic Actuation

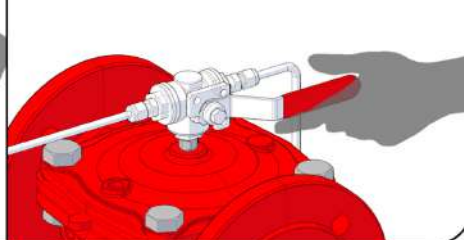

Typical Installation

The typical installation of the OCV MO\EL Electrically Actuated Fire Water Monitor Valve is as shown:

- 1 OCV MO\EL - Electrically Actuated Monitor Valve
- 2 3/2-Way N.O. Solenoid
- 3 Local Manual Actuation Valve
- 4 F&G Panel
- 5 Remote Controlled Fire Water Monitor Valve

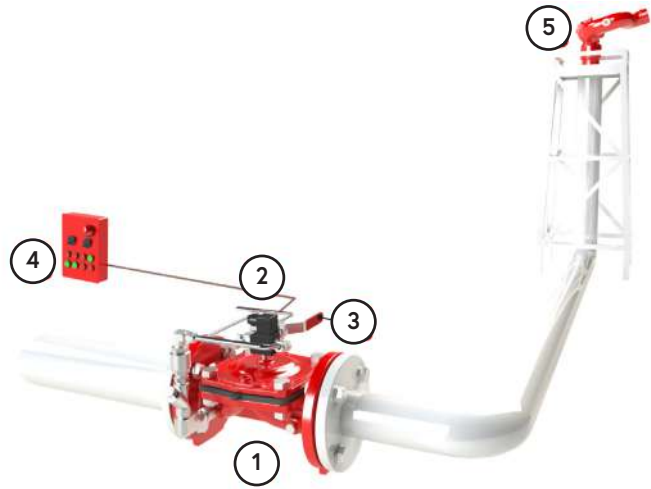

The typical installation of the OCV MO\EL Electrically Actuated Monitor Valve with Optional Foam Solution Valve is as shown:

- 1 OCV MO\EL - Electrically Actuated Monitor Valve
- 2 OCV ZP\EL - Foam Concentrate Electrically Actuated Control Valve
- 3 3/2-Way N.O. Solenoid
- 4 Local Manual Actuation Valve
- 5 F&G Panel
- 6 66-213 Relay Valve
- 7 Foam Proportioner
- 8 Remote Controlled Fire Water Monitor Valve

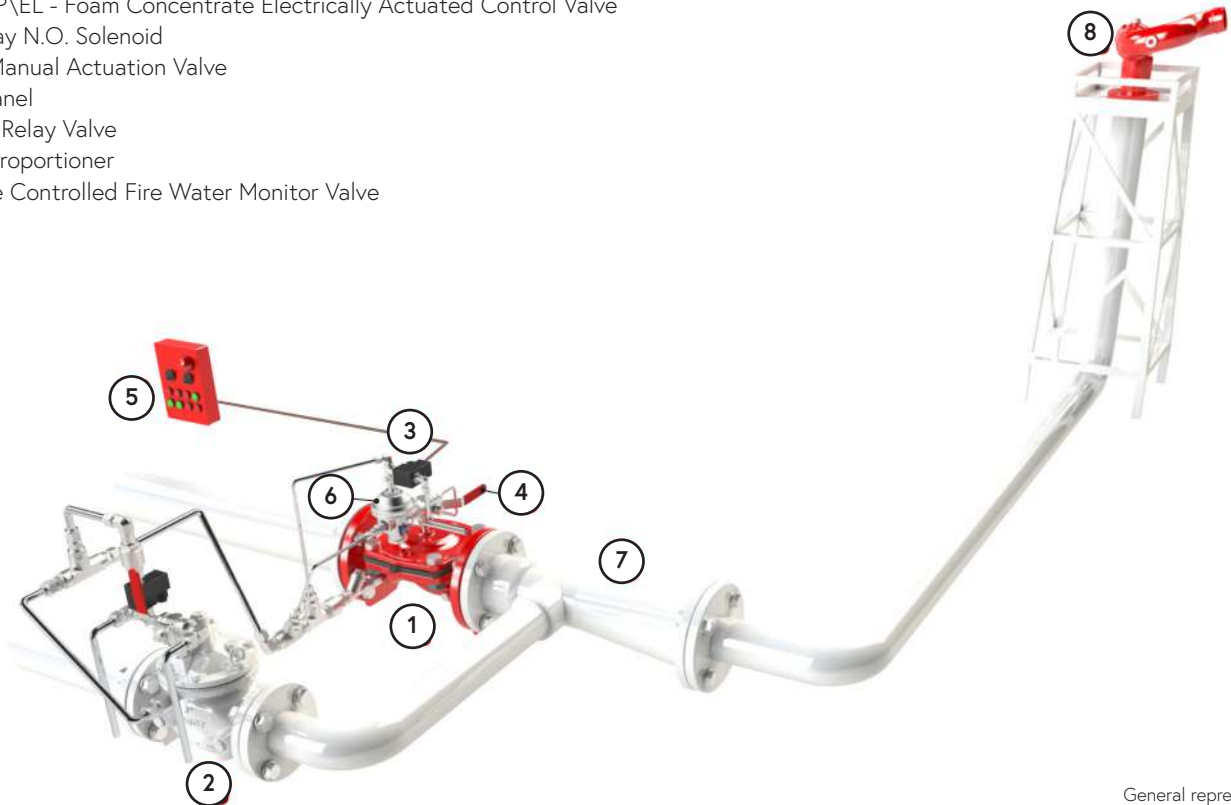

General representation.
Not all items pictured reflect products sold by OCV.

Technical Data

Temperature (Elastomers)	
Media	Media up to 85°C = 185°F
Elastomers	suitable for extreme climates (available upon request)
Sizes	
Straight Flow	Sizes: 2" - 24"
Lloyd's Type Approved Size	Model 68 (Flanged): 2" - 10" Model 77 (Flanged): 2" - 24" Model 44 (Threaded): 1" - 3"
Pressure Rating	
250psi for Class 150#	Models 44 & 77: up to 16 bar / 230psi
375psi for Class 300#	Model 68: up to 25 bar / 375psi
End Connections	
Flanged	ISO-PN16 & ISO-PN25
	ANSI B16.42 & B16.5 Class 150# & 300#
	Additional options available upon request
Grooved	Sizes: 2"- 8"
Threaded	Sizes: 1"- 3"

Body & Cover Material	
Ductile Iron	Stainless Steel
Cast Steel	NAB
Trim Material	
Bronze/Brass - Copper	
Stainless Steel	
Monel	
Optional Components	
Upstream Drain Valve	
Pressure Switch	
Limit Proximity Switch	
Items to Specify	
Electrical features other than standard (24VDC, IP65/NEMA4)	
If explosion proof accessories are required such as solenoids, pressure switches, etc., please define classification	
Control trim material other than standard	
Required standards, certifications and approvals	

Engineering Specifications

The monitor valve shall be hydraulically operated, direct elastomeric diaphragm-seal, single chamber weir type. The valve shall consist of three major components: the body, the cover and the diaphragm assembly. The diaphragm assembly shall be the only moving part. The diaphragm forms a sealed control chamber in the upper portion of the valve, separating operating pressure from line pressure. Packing glands, stuffing boxes and dynamic o-ring seals are not permitted and there shall not be shafts, discs, bearings or pistons operating the valve. No hourglass shaped disc retainers shall be permitted, and no V-type, U-type or other slotted type disc guides shall be used. The valve shall contain a nylon reinforced rubber diaphragm, elastic & resilient through its entire surface without vulcanized radial seals and/or reinforcements. The diaphragm assembly shall not be guided

by any shafts or bearings and shall not be in close contact with other valve parts except for its sealing surface. The monitor valve shall be fully trimmed, hydrostatically and operationally tested at the factory. Maintenance, disassembly and reassembly of all the valve's components shall be made possible on-site and in-line, without the need to remove the valve from the line. Main valve body and bonnet standard material shall be ductile iron or cast steel. Main valve body and bonnet surfaces shall include a fire red epoxy coating. Other materials and coatings available upon request. The monitor valve shall be an OCV Series 100 Model MO\M, MO\RC or MO\EL, Lloyd's Type Approved, as manufactured by OCV, an Aquestia Ltd. brand, Tulsa, OK, USA.