

## Pressure Reducing & Pressure Relief Valves



General representation



Fire  
Protection

## Pressure Reducing Valve

### Description

An automatic, pilot controlled, pressure reducing valve actuated by the pipeline pressure. The valve regulates to a steady, preset downstream pressure regardless of upstream pressure or flow rate fluctuations. In case of excessive downstream pressure, the valve closes drip tight.

### Certification & Compliance

UL Listed under VLFT category



Lloyd's Register Approval



ANSI FCI 70-2 Class VI seat leakage class

### Features & Benefits

- Simple field adjustable pressure setting; no special tools & no system downtime
- Superior design featuring low pressure losses at high flow rates
- Low lifelong maintenance costs due to unique frictionless internal trim design
- High flows & working pressures (PN25/375psi)
- Stable regulation from near zero flow to maximum design flow
- Regulates at low flow & high pressure differential without bypass or U/V port design
- Out of the box fully assembled & tested valves
- Extensive valve & trim materials selection & corrosion protection coating
- Stainless Steel seat as standard

### Typical Applications

Pump & Water Tanks

Fire Suppression Systems

Petrochemical, Oil & Gas Installations

Tunnels



Power Generation, Transformer & Transmission Plants

Onshore/Offshore

Mining



## Operation

The OCV 30 PR\UL is a pilot-controlled, pressure reducing valve, actuated by the pipeline pressure. The valve accurately regulates to a steady, preset downstream pressure, down to near-zero flow rates, regardless of upstream pressure fluctuations and valve size. In case of excessive downstream pressure, the valve closes drip tight. The valve's unique design eliminates the need for a special low-flow plug design (such as V or U-ports), or the installation of additional smaller-sized bypass valves.

The valve's low-friction internal trim design utilizes an LTP® (Linear Throttling Plug) guide and a preshaped reinforced diaphragm. The standard and simple single chamber valve allows easier assembly, improved longevity and reduces periodic inspections and maintenance. When required, maintenance is easily done onsite and in-line.

When planning operation and design, please consider the following:

- The valve should be suited to the maximum designed flow and allowed head loss.
- For added safety, installing a downstream pressure relief valve (30 PS\UL, 77 PS\UL, 44 PS\UL or 108FCA) is highly recommended.
- Large pressure differentials may cause cavitation damage. Consult OCV for unique solutions if such conditions are expected.

Closed Position

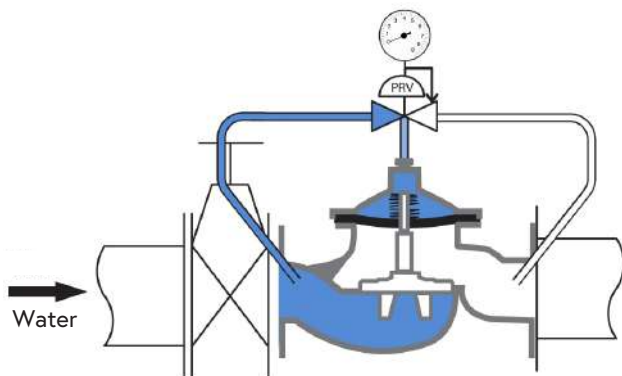

Regulating Position

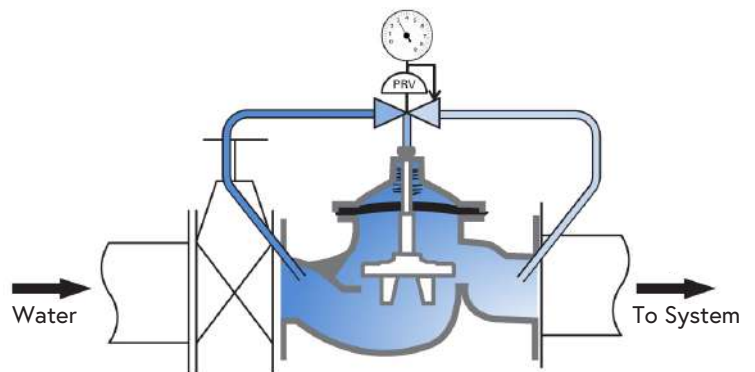

Resetting, maintenance, and periodic testing instructions must be followed as described in detail in the applicable OCV IOM (Installation, Operation & Maintenance) Manual.

## Components & Typical Materials

The OCV 30 PR\UL consists of the following components, arranged as shown on the schematic diagram below.

ID	Part	Standard Material	POG (1) Applications
1	Valve Body	See OCV 300 Engineering Data (2)	
2	Inline Strainer	Brass, Stainless Steel Screen	Stainless Steel 316
3	Pressure Gauge	Brass	Stainless Steel 316
4	Pressure Reducing Pilot	Brass, Stainless Steel 316 Seat	Stainless Steel 316
5	Position Indicator	Stainless Steel 316	Stainless Steel 316

(1) Petrochemical, Oil & Gas

(2) Refer to materials selection guidelines, Engineering Data - Materials: Ductile Iron A-536 65-45-12; Cast Steel A-216 WCB; Cast Steel A-352 LCB; Austenitic Stainless Steel A-351/CF8M; Super Duplex 2507; Nickel-Aluminum-Bronze B-148 UNS C95800

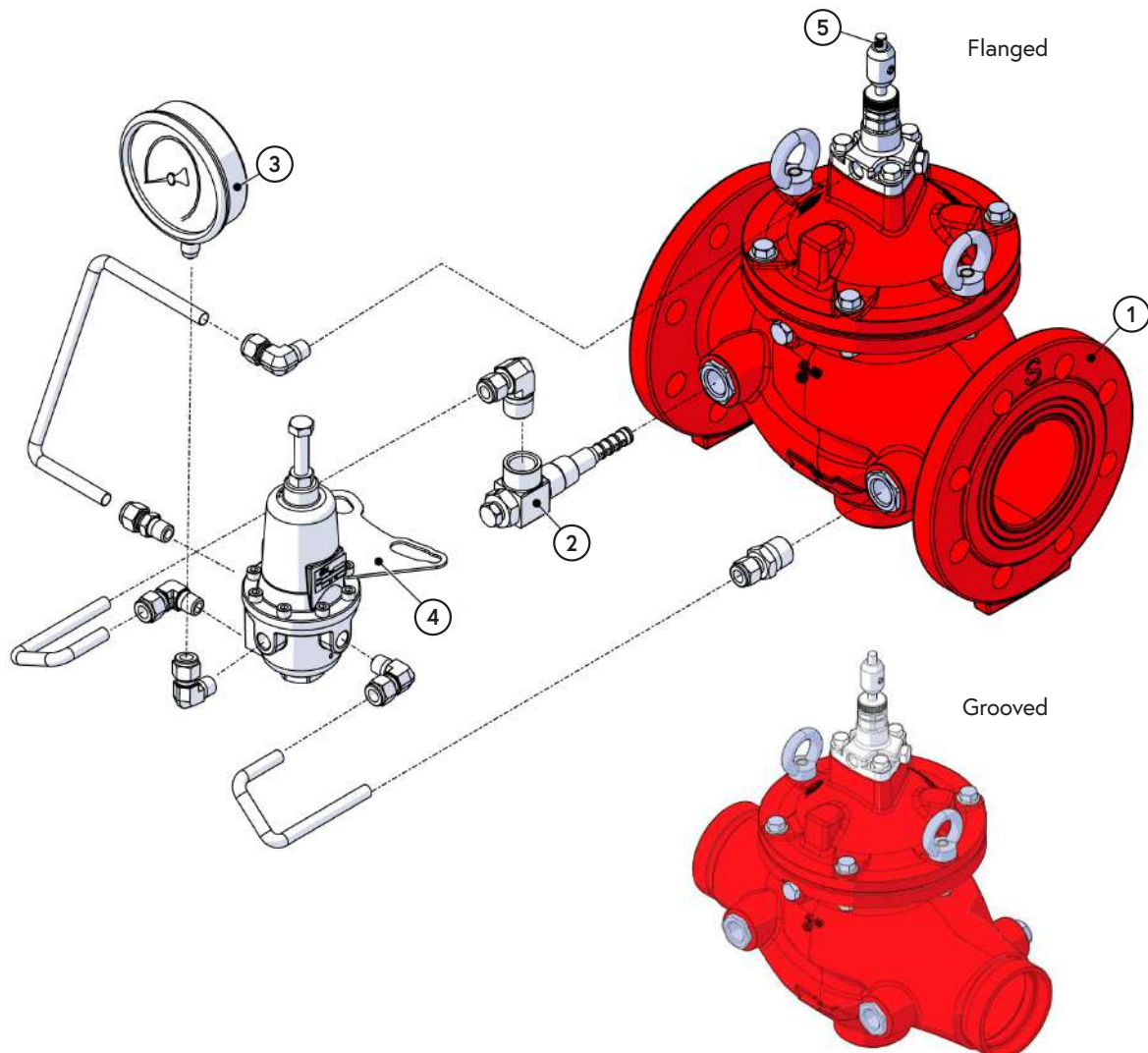

## General Arrangement & Dimensions

Standard Sizes								
DIM	2"	2 1/2"	3"	4"	6"	8"	10"	12"
A	9 1/8	11 3/16	12 3/16	13 13/16	18 7/8	23 5/8	28 13/16	33 1/2
A <sub>G</sub>	8 1/2	8 1/2	13 13/16	14 13/16	20 1/2	--	--	--
B	6 1/8	6 1/8	6 1/8	6 7/8	9 1/2	11 13/16	14 3/8	16 11/16
C	7 7/8	7 7/8	9 3/16	10	11 7/8	13 1/2	15 11/16	17 3/16
D	3 5/16	3 5/8	3 7/8	4 5/16	5 5/8	6 13/16	8 1/8	9 1/8
E	9 5/16	9 5/16	11 5/8	12 1/8	15 3/8	17 13/16	22 1/2	26 5/16

Approximate Dimensions.

Metric Sizes								
DIM	DN50	DN65	DN80	DN100	DN150	DN200	DN250	DN300
A	230	290	310	350	480	600	730	850
A <sub>G</sub>	215	215	350	376	520	--	--	--
B	155	155	155	175	240	300	365	425
C	200	200	234 1/2	253 1/2	301	342 1/2	399 1/2	436
D	82 1/2	92 1/2	100	110	142 1/2	172 1/2	205	230
E	236	236	295	307	390	452	572	668

Approximate Dimensions.

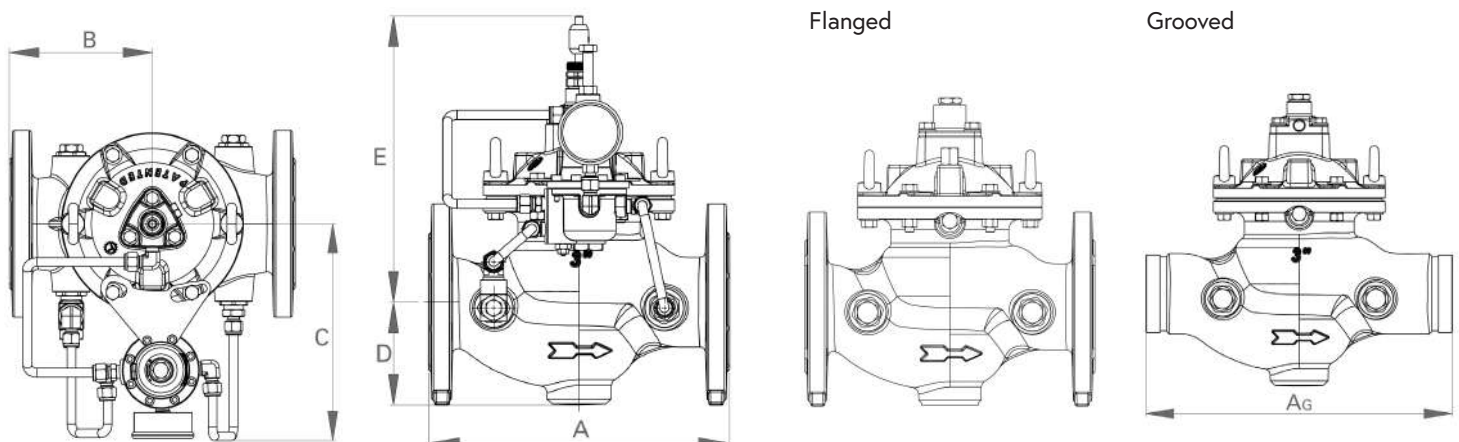

## Typical Installation

The typical installation of the OCV 30 PR\UL is as shown:

- 1 Pressure Gauge
- 2 Isolation Valve
- 3 Strainer
- 4 OCV 30 PR\UL Pressure Reducing Valve
- 5 Recommended Models: OCV 44, 77, 30 or OCV 108FCA Pressure Relief Valves

### Typical System Layout

Pressure Reducing Station Layout  
Including Downstream Pressure  
Relief Valve

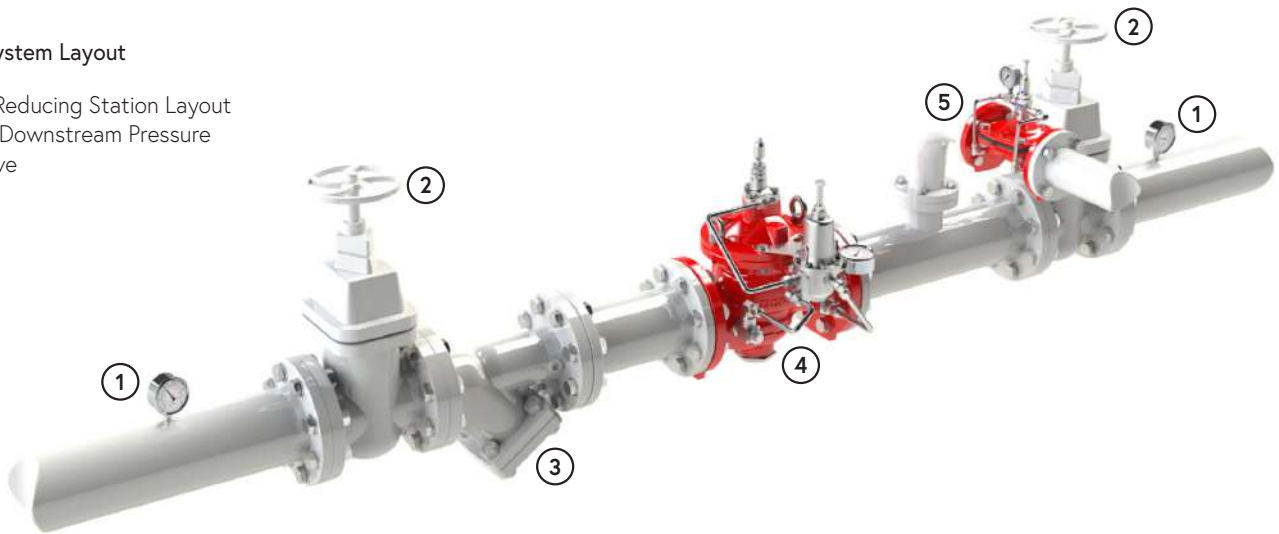

### Optional System Layout for Redundancy

Similar to the typical installation -  
while providing extra redundancy &  
zero downtime during inspection &  
maintenance.

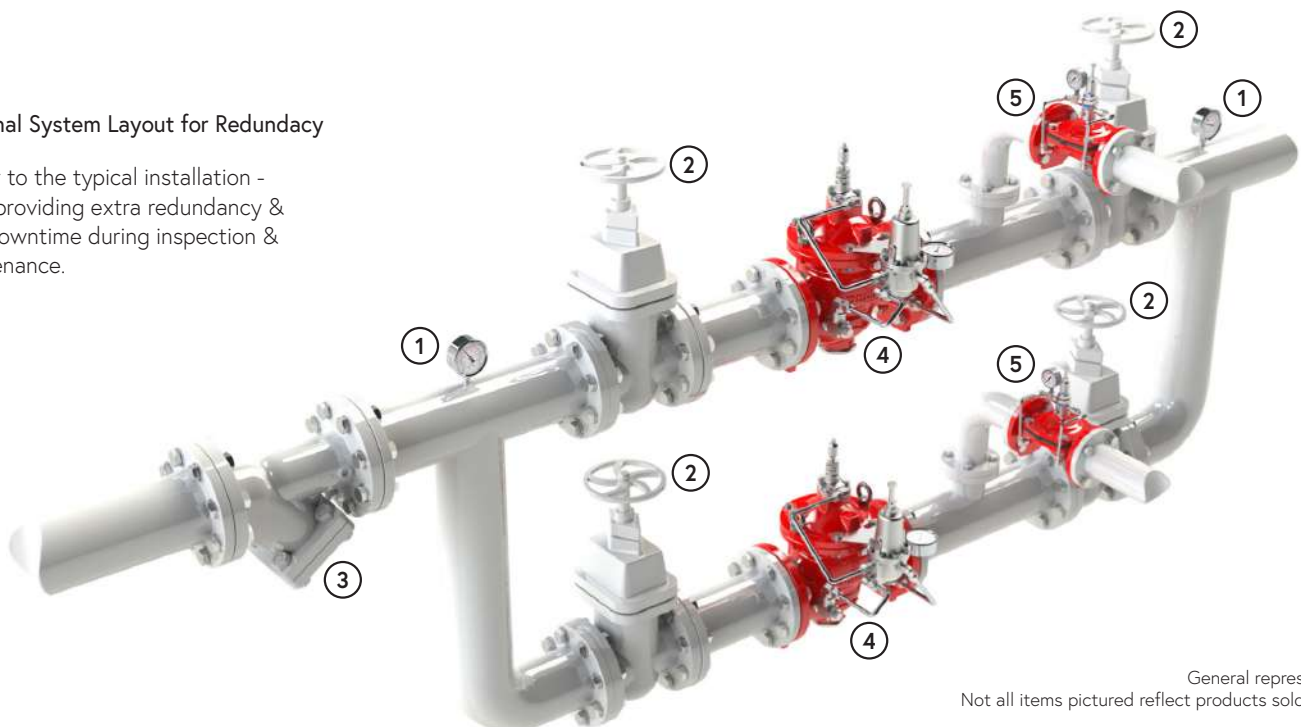

General representation.  
Not all items pictured reflect products sold by OCV.

## Technical Data

Temperature (Elastomers)	
Media	up to 80°C = 176°F
Elastomers	suitable for extreme climates (available upon request)
Sizes	
UL Listed	2" - 6"
Pressure Rating (ANSI at 100°F)	
250psi for Class 150#	
375psi for Class 300#	
End Connections	
Flanged	ISO-PN16 & ISO-PN25
	ANSI B16.42 & B16.5 Class 150# & 300#
	Additional options available upon request
Grooved & Threaded	Available

Body & Cover Material	
Ductile Iron	Stainless Steel
Cast Steel	NAB
Trim Material	
Brass - Copper	
Stainless Steel	
Optional Components	
Pressure Switch	
Limit/Proximity Switch	
Items to Specify	
Control trim material other than standard	
Required standards, certifications and approvals	
UL Listed Downstream Pressure Setting Range	
2" - 6" = 30-165psi	
Other Certified (non UL) Downstream Pressure Setting Range	
2" - 8" = 30-360psi	
10" - 12" = 30-285psi	

## Engineering Specifications

The pressure control valve shall contain a fabric reinforced rubber diaphragm, elastic & resilient through its entire surface without vulcanized radial discs. The seat shall be stainless steel and interchangeable. The valve shall maintain a constant predetermined downstream pressure regardless of upstream pressure or flow rate fluctuations. Maintenance, disassembly and reassembly of all the valve's components shall be made possible onsite and in-line, without the need to remove the valve from the line. The valve shall be fully trimmed, hydrostatically and operationally tested at the factory and set to a fixed pressure. Change of factory preset pressure setting

can always be performed in-line following simple IOM instructions, without special tools or system downtime. Standard material valves such as ductile iron and cast steel should be coated with high-built fusion-bonded epoxy (FBE). Naval quality/very high corrosivity protection grade conforming to EN12944 C5M is available upon request. Additional coatings and special materials are available upon request. The pressure control valve shall be an OCV 30 PR\UL, UL Listed under VLMT category, as manufactured by OCV, an Aquestia Ltd. brand, Tulsa, OK, USA.