

OCV Model 1330FC

Pressure Reducing & Pressure Relief Valves

Aquestia
Directing the Flow



General representation



Fire
Protection

Thermal Expansion Relief Valve

Description

This is a pressure relief valve that is installed downstream of a pressure reducing valve and is located in the distribution piping in a fire protection system. If the pressure in the distribution piping rises above the relief valve's set point, the OCV 1330FC opens and relieves the excess pressure, thus preventing damage.

Certification & Compliance

UL Listed (Control Number 39TZ)



Features & Benefits

- Normally closed, increasing inlet pressure opens valve
- UL listed spring range of 20-175 psi
- Local sense line (self contained sense loop)
- Simple adjustment
- All parts replaceable while valve is installed
- Rubber to metal seat for positive shutoff
- Can be installed vertically or horizontally
- Sizes 1/2", 3/4", 1"
- Applicable for water, seawater & foam

Typical Installation

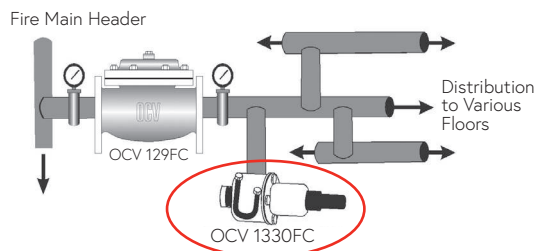

Technical Data

Material	Part Number	Inlet/Outlet (NPT)
Stainless Steel, Buna-N	230838	1/2"
Stainless Steel, Buna-N	230842	3/4"
Stainless Steel, Buna-N	230843	1"

Spring Ranges			
Part Number	Color	Range PSI	Range kPa
651701*	Green	5-30	35-210
651703*	Red (1 1/4" long)	20-80	140-560
651000	Red (2" long)	20-200	138-1379
651702*	Blue	100-300	700-2100

*Non-UL Listed Spring

1. Body
2. Bonnet
3. Adaptor
4. Plug
5. Diaphragm
6. Seat Disc
7. Stem
8. Diaphragm Plate
9. Spring
10. Adjusting Screw
11. Spring Retainer
12. Cap

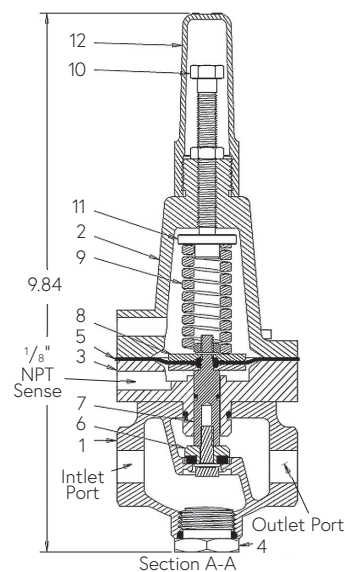

Aquestia Ltd. reserves the right to make product changes without prior notice. To ensure receiving updated information on parts specifications, please contact us at usa@aquestia.com. Aquestia Ltd. shall not be held liable for any errors. All rights reserved.

Aquestia USA