

Deluge Valves



General representation



Fire
Protection

Pneumatically Actuated Deluge Valve

Description

Pneumatically actuated, pilot controlled deluge valve, actuated by the pipeline pressure. The valve is closed in its normal, set position and opens when the pneumatic supply pressure is removed. An emergency manual release valve is fitted as standard.

Certification & Compliance

UL Listed under VLFT category (3"-10")

ABS Type Approval

ANSI FCI 70-2 Class VI seat leakage class

Fire tested to EN ISO 19921



Features & Benefits

- Opens quickly when the pneumatic supply pressure is removed
- Manual override to open the valve regardless of pneumatic pilot position
- Visual indicator identifies valve position
- Large supply drain port to drain inlet side piping
- Pilot operated main valve
- No adjustments are necessary
- Factory tested
- Can be installed vertically or horizontally
- ANSI Flanged Class 150# or Class 300#
- Wide range of materials available
- Options available including opening and/or closing speed controls, limit switch assembly and pressure gauge(s)

Typical Applications

Automatic or Manual Actuated Fire Suppression Systems

Petrochemical, Oil & Gas Installations

Tunnels

Power Generation, Transformer & Transmission Plants



Flammable Storage

Hangers & Airport Terminals

Onshore/Offshore

Mining



Operation

The basic control valve [1] used in this deluge system is a diaphragm actuated globe valve that closes with an elastomer-on-metal seal, hydraulically operated control valve engineered specifically for fire protection systems.

In the standby position, the deluge valve is held closed by the upstream water pressure, trapped in the valve's control chamber. The water pressure enters the control chamber through the priming line ball valve [5A], a Y-type strainer [4] and an ejector [3].

Under fire conditions, pneumatic pressure is removed. The pressure in the pneumatic pilot [2] drops, causing it to open and allowing the water to drain from the deluge valve's control chamber. The deluge valve opens instantly and allows water to flow into the pipeline and through the open sprinklers over the protected area.

Manual emergency actuation is enabled by opening the emergency manual activation valve [5B]. The deluge valve opens instantly and allows water to flow into the pipeline and through the open sprinklers over the protected area.

A visual indicator [6] provides indication of the valve's position at a glance.

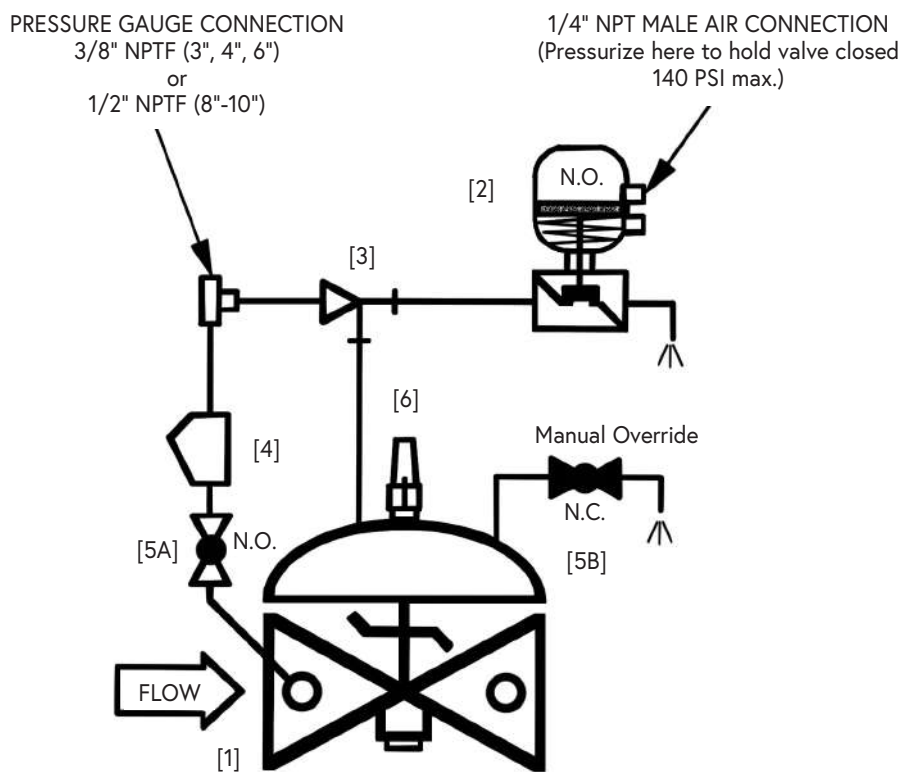

Components & Typical Materials

The OCV 116FC consists of the following components, arranged as shown on the schematic diagram below.

Part	Standard Material	Optional
Valve Body	Ductile Iron	Cast Steel, Stainless Steel, NAB, Duplex Stainless Steel
Seat Ring	Bronze	Stainless Steel, NAB, Duplex Stainless Steel
Stem	Stainless Steel	Monel
Spring	Stainless Steel	Elgiloy/MP35N
Diaphragm	Nylon Reinforced Buna-N	E.P.D.M.
Pneumatic Pilot	Stainless Steel	---
Tubing/Fittings	Copper, Bronze/Brass	Stainless Steel, Monel

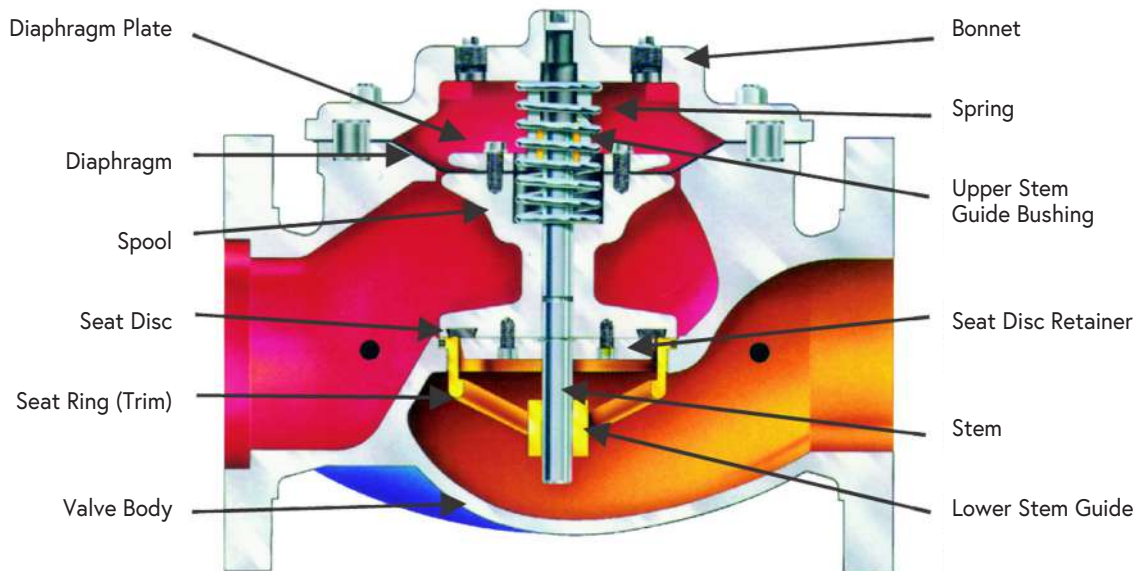

General Arrangement & Dimensions

Standard Sizes						
DIM	END CONNECTIONS	3"	4"	6"	8"	10"
A	150# Flanged	12	15	17 ³ / ₄	25 ³ / ₈	29 ³ / ₄
	300# Flanged	12 ³ / ₄	15 ⁵ / ₈	18 ⁵ / ₈	26 ³ / ₈	31 ¹ / ₈
B	150# Flanged	3 ³ / ₄	4 ¹ / ₂	5 ¹ / ₂	6 ³ / ₄	8
	300# Flanged	4 ¹ / ₈	5	6 ¹ / ₄	7 ¹ / ₂	8 ³ / ₄
E	ALL	6 ¹ / ₂	8	10	11 ⁷ / ₈	15 ³ / ₈
F	ALL	3 ⁷ / ₈	3 ⁷ / ₈	3 ⁷ / ₈	6 ³ / ₈	6 ³ / ₈
H	ALL	11	12	13	14	17

Approximate Dimensions.

Metric Sizes						
DIM	END CONNECTIONS	DN80	DN100	DN150	DN200	DN250
A	150# Flanged	305	381	451	645	756
	300# Flanged	324	397	473	670	791
B	150# Flanged	95	114	140	171	203
	300# Flanged	105	127	159	191	222
E	ALL	165	203	254	302	391
F	ALL	98	98	98	162	162
H	ALL	279	305	330	356	432

Approximate Dimensions.

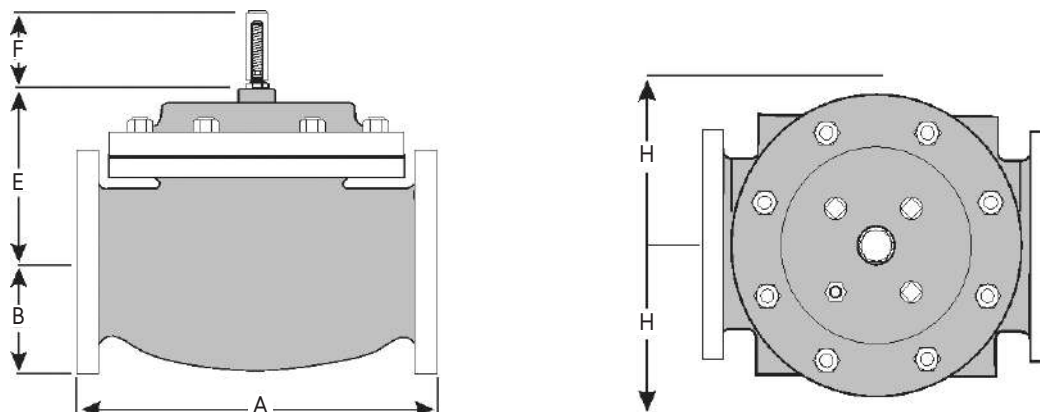

Typical Installation

The typical installation of the OCV 116FC is as shown:

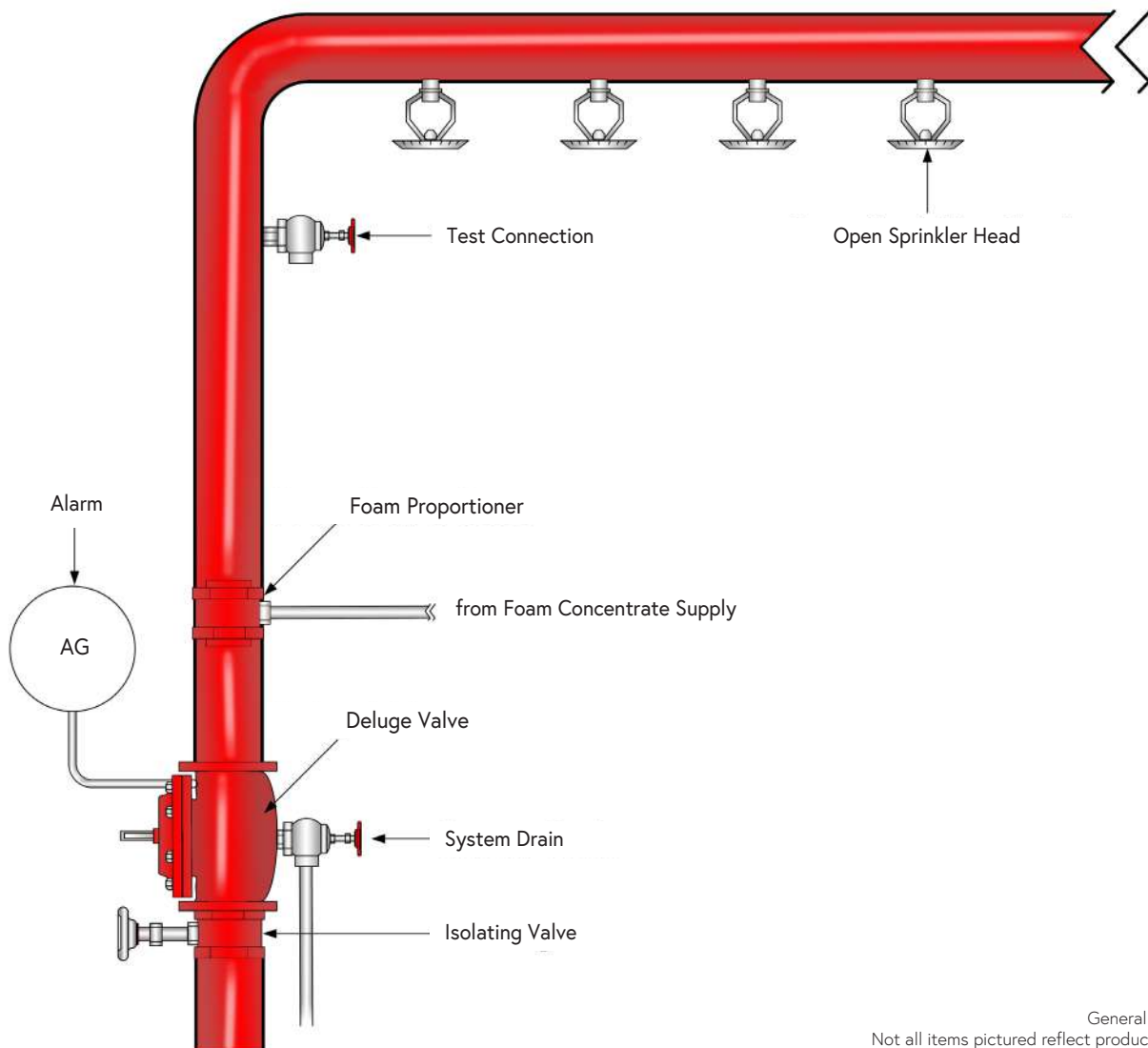

General representation.
Not all items pictured reflect products sold by OCV.

Flow Characteristics

Standard Sizes	3"	4"	6"	8"	10"
Globe Cv	120	200	450	760	1250
Metric Sizes	DN80	DN100	DN150	DN200	DN250
Globe Kv	103 ⁴ / ₅	173	389 ³ / ₁₀	657 ² / ₅	1081 ¹ / ₅

Technical Data

Temperature (Elastomers)	
Media	up to 80°C = 176°F
Elastomers	suitable for extreme climates (available upon request)
Sizes	
UL Listed Model 68	2" - 10"
Straight Flow	2" - 24"
Pressure Rating (ANSI at 100°F)	
250psi for Class 150#	
375psi for Class 300# are available	
End Connections	
Flanged	ISO-PN16 & ISO-PN25
	ANSI B16.42 & B16.5 Class 150# & 300#
	Additional options available upon request
Grooved	Sizes: 2"-8"

Body & Cover Material	
Ductile Iron	Stainless Steel
Cast Steel	NAB
Trim Material	
Pneumatic Pilot	Stainless Steel
Tubings/Fittings	Copper, Bronze/Brass
Optional Fittings	Stainless Steel, Monel
Optional Components	
Position Indicator	
Alarm Test Trim	
Upstream Drain Valve	
Pressure Switch	
Limit/Proximity Switch	
Spring	
Items to Specify	
Electrical features other than standard (24VDC, IP65/NEMA4)	
If explosion proof accessories are required such as solenoids, pressure switches, etc., please define classification	
Control trim material other than standard	
Required standards, certifications and approvals	

Engineering Specifications

The deluge valve shall be hydraulically operated, direct elastomeric diaphragm-seal, single chamber weir type. The valve shall consist of three major components: the body, the cover and the diaphragm assembly. The diaphragm assembly shall be the only moving part. The diaphragm forms a sealed control chamber in the upper portion of the valve, separating operating pressure from line pressure. Packing glands, stuffing boxes and dynamic o-ring seals are not permitted and there shall not be shafts, discs, bearings or pistons operating the valve. No hourglass shaped disc retainers shall be permitted, and no V-type, U-type or other slotted type disc guides shall be used. The valve shall contain a nylon reinforced rubber diaphragm, elastic & resilient through its entire surface without vulcanized radial seals

and/or reinforcements. The diaphragm assembly shall not be guided by any shafts or bearings and shall not be in close contact with other valve parts except for its sealing surface. The deluge valve shall be fully trimmed, hydrostatically and operationally tested at the factory. Maintenance, disassembly and reassembly of all the valve's components shall be made possible on-site and in-line, without the need to remove the valve from the line. Main valve body and bonnet standard material shall be ductile iron or cast steel. Main valve body and bonnet surfaces shall include a fire red epoxy coating. Other materials and coatings available upon request. The deluge valve shall be an OCV 116FC, UL Listed under VLFT category, as manufactured by OCV, an Aquestia Ltd. brand, Tulsa, OK, USA.