



# 68P-DE\PORV\PR-MR

Pneumatically Actuated, Manual-Reset  
Pressure Reducing Deluge Valve

## IOM

**I**nstallation • **O**peration • **M**aintenance



## Installation, Operation & Maintenance

This document specifies the operating concept of OCV deluge valve model 68P-X-DEIPORV\PR-MR (X refers to valve size in Inch), UL listed when trimmed per the following technical data sheet

Please review the safety instructions at the end of this document prior to commissioning the valve for use

## DELUGE PRESSURE REDUCING VALVE MODEL 68P-DE\POR\PR-MR

### General Description

OCV's pressure regulating, deluge and pre-action valve model 68P-X-DE\POR\PR-MR is a globe-weir-type hydraulic valve, actuated automatically or manually. The valve is mounted on the upstream side of a fire-suppression sprinkler system, preventing flow into the system in its "ready" position.

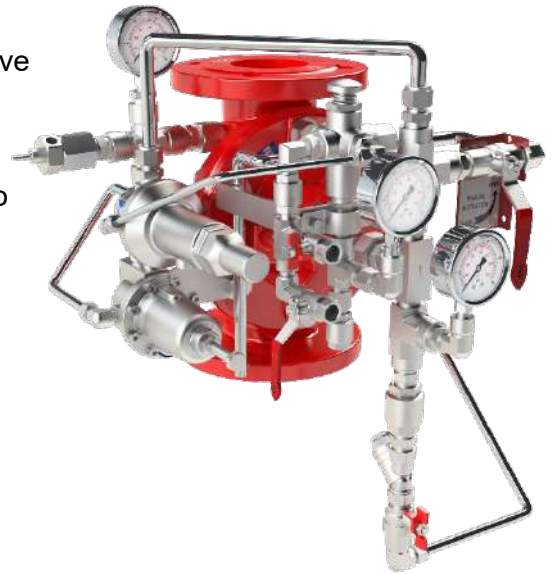

#### Pressure rating

- Pressure rating up to 25 bar \ 375 psi
- Minimum system pressure 1.5 bar \ 22 psi

#### UL listed outlet pressure setting range

- 2" - 10": 20 bar \ 300 psi

#### Available end connections

- Flanged: 2" – 10" (Including 2.5")
- Grooved: 2" – 8" (Including 2.5")

#### Available body & cover and trim materials

Body & Cover	Valve Fitting	Valve Tubing	Diaphragm
Ductile Iron A536*	Brass*	Copper*	Neoprene*
CF8M/ASTM A-316	SST316	Cu-Ni 90/10	NR
Ni-Al-Bronze ASTM B148 gr.C95800	SST304 ASTM A 351	SST316	EPDM
Cast Steel ASTM A 216 WCB	Super Duplex 2507	Super Duplex 2507	NBR
	Aluminum-Bronze		
	MONEL®		

\* Standard material

## DELUGE PRESSURE REDUCING VALVE MODEL 68P-DE\PORV\PR-MR

### General Description

#### Deluge valve actuation:

1. The deluge valve is actuated when pressure in the pilot-line drops below a preset value.
2. In case of failure of the automatic actuation system, manual emergency actuation is possible.
3. Automatic actuation causes the DMR [m] to seal shut the connection between the instrument air pressure source and the 66-2UL relay [k] thus latching it open.  
Reconnecting the instrument air pressure source and the 66-2UL relay's [k] control chamber, thus resetting the deluge valve, can only be accomplished by pressing the DMR's [m] knob.
4. When actuated the deluge valve limits the downstream pressure to a fixed & steady pre-set value, regardless of upstream pressure or flow fluctuations.

#### Manual emergency actuation:

1. The manual emergency actuation valve [b2] may be located inside a metal box or over a plate. If in a box – first lift the cover - and turn the handle as shown on the plaque in the box.

#### Closing the deluge valve is possible only after:

1. Restoring pressure in the pilot-line.
2. Closing the manual emergency actuation ball valve [b2].
3. Manual-reset by holding the DMR's [m] knob until the deluge valve closes.

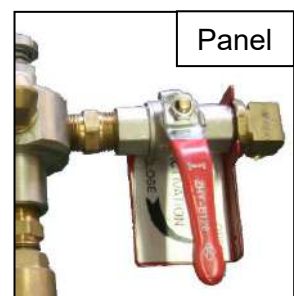

## **DELUGE PRESSURE REDUCING VALVE MODEL 68P-DE\POR\PR-MR**

### **Pre-Installation Recommendations (refer to fig. 2 – System P&ID)**

1. The valve is factory trimmed for both vertical and horizontal installation - out of the box, requiring no changes or tooling.
2. The valve may be installed either vertically (with the upstream positioned at the bottom) or horizontally.
3. Sufficient space for maintenance should be left around the deluge valve.
4. Manual isolating valves (gate type, butterfly type or equivalent - not supplied) should be assembled upstream and downstream of the deluge valve for maintenance purposes.
5. A drain facility for the water drained during the valve's test & working procedures should be prepared.

**Fig. 1- General layout**

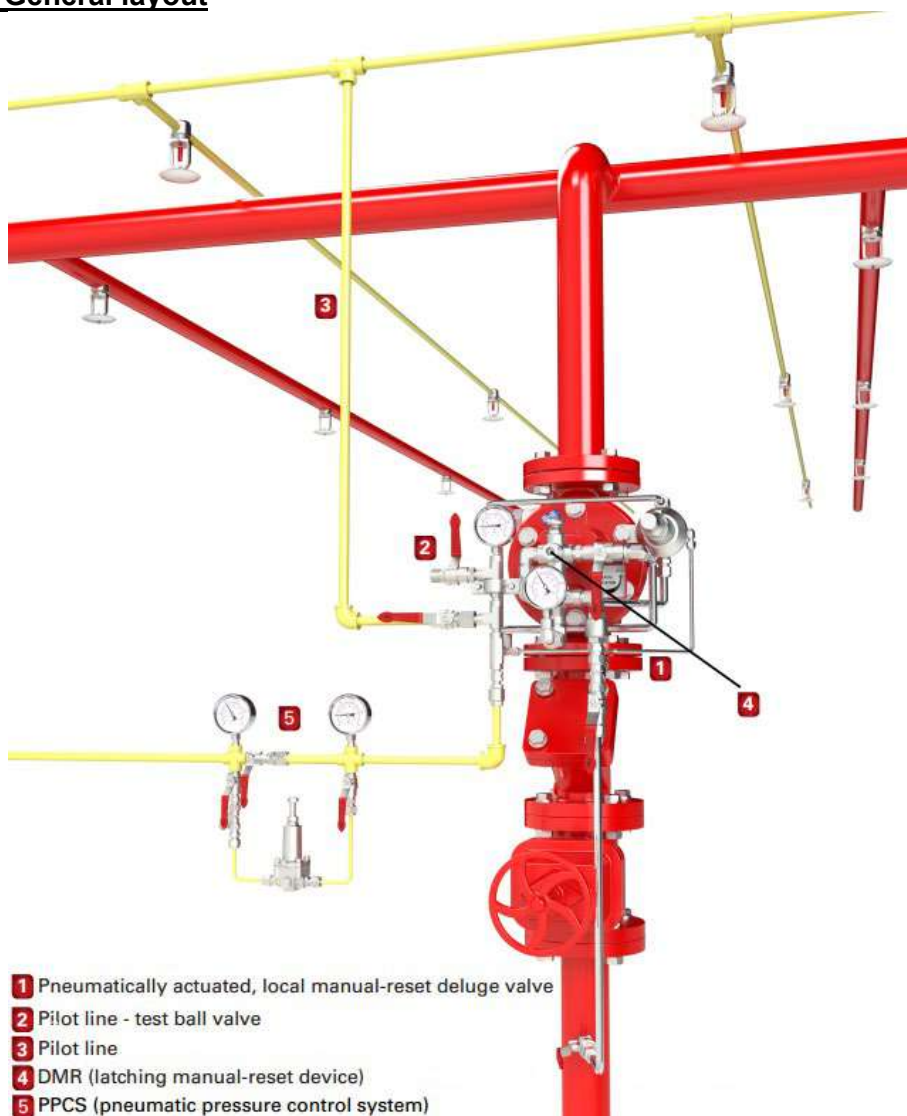

## **DELUGE PRESSURE REDUCING VALVE MODEL 68P-DE\PORV\PR-MR**

### **Installation** (refer to fig. 2 – System P&ID)

1. The deluge valve should be positioned in such a way that allows easy access to the emergency manual actuation valve [b2].
2. The priming control trim's ball valve [b1] should be connected to the deluge valve's upstream port.
3. Connect the water motor alarm (optional) to the alarm trim's isolation ball valve [b5].
4. Connect the pilot-line to the pilot-line's isolation ball valve [b6].
5. Connect the check valve [d1] to an instrument air supply unit.
6. The drain valve [j], the outlet pipes of the pilot-line's test ball valve [b7] and the emergency manual valve [b2], should be drained.

## DELUGE PRESSURE REDUCING VALVE MODEL 68P-DE\PORV\PR-MR

**Fig. 2- System P&ID**

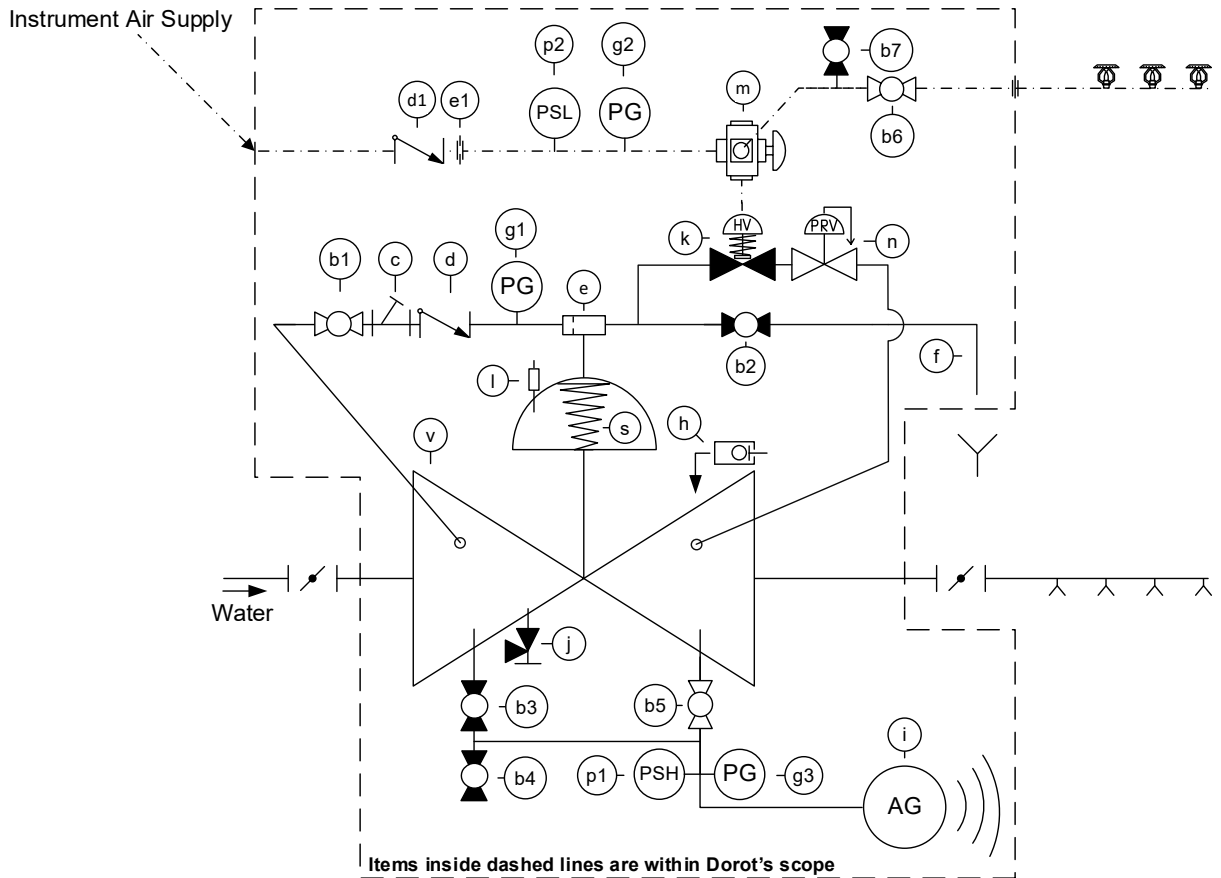

Integral System items	
Item #	Description
v	Hydraulic valve
b1	Priming line ball valve
b2	Emergency manual activation valve
b6	Pilot-line - isolation ball valve
b7	Pilot-line - test ball valve
c	Y-Type strainer
d, d1	Check valve
e	T Restrictor
e1	Restrictor
f	1/2" tube
g1, g2	Pressure gauge
h	Drip valve
k	66-2UL-relay
m	DMR (latching manual-reset device)
n	CXPR pressure reducing pilot
s	Spring

Optional System items	
Item #	Description
b3	Alarm trim - test ball valve
b4	Alarm trim - drain\purge ball valve
b5	Alarm trim - isolation ball valve
g3	Pressure gauge
i	Water motor alarm
j	Drain valve
l	Indicator Rod
p1	Pressure switch high - water
p2	Pressure switch low - gas

## DELUGE PRESSURE REDUCING VALVE MODEL 68P-DE\PORV\PR-MR

**Fig. 3- System P&ID – with regulated manual emergency actuation**

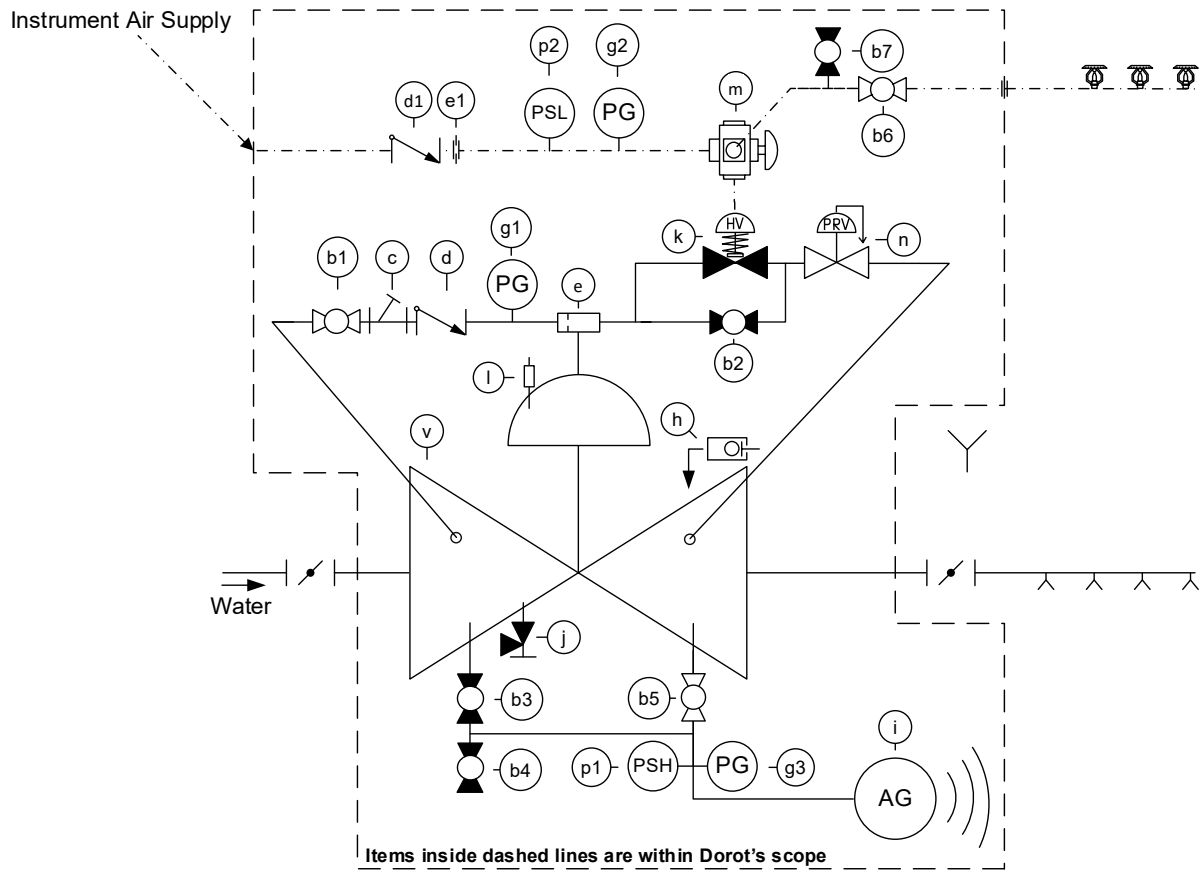

Integral System items	
Item #	Description
v	Hydraulic valve
b1	Priming line ball valve
b2	Emergency manual activation valve
b6	Pilot-line - isolation ball valve
b7	Pilot-line - test ball valve
c	Y-Type strainer
d, d1	Check valve
e	T Restrictor
e1	Restrictor
f	1/2" tube
g1, g2	Pressure gauge
h	Drip valve
k	66-2UL-relay
m	DMR (latching manual-reset device)
n	CXPR pressure reducing pilot
s	Spring

Optional System items	
Item #	Description
b3	Alarm trim - test ball valve
b4	Alarm trim - drain\purge ball valve
b5	Alarm trim - isolation ball valve
g3	Pressure gauge
i	Water motor alarm
j	Drain valve
l	Indicator Rod
p1	Pressure switch high - water
p2	Pressure switch low - gas



## **DELUGE PRESSURE REDUCING VALVE MODEL 68P-DE\PORV\PR-MR**

### **Control Trim Connection (refer to fig. 2 – System P&ID)**

1. The upstream control trim includes the following items:
  - Priming control trim's ball valve [b1].
  - Y-Type strainer [c].
  - Check valve [d].
  - T-restrictor [e].
2. The 66-2UL relay [k] has two positions:
  - 'Closed' - prevents draining of the deluge valve's control chamber.
  - 'Open' - allows draining of the control chamber, thus instantly opening the deluge valve, causing the DMR [m] to latch closed.
3. The pressure reducing pilot valve [n] is connected to a downstream port of the deluge valve. When actuated, the deluge valve limits the downstream pressure to a fixed & steady pre-determined value, regardless of upstream pressure or flow fluctuations.
4. A water motor alarm [i] may be connected to the deluge valve via an optional alarm trim. The alarm trim consists of:
  - Ball valve [b5], which is normally-open.
  - Ball valve [b3], which is normally-closed and allows testing the alarm without opening the deluge valve.
  - Ball valve [b4], which is normally-closed and allows draining the alarm trim and purging it from corrosive fluids if necessary.
5. A low-pressure drip valve (relief valve) [h], is mounted on a downstream port of the deluge valve, as a safety device against faulty sealing of the deluge valve, which may be caused by foreign objects or unclean water. The drip valve allows small quantities of water to be drained from the system but shuts instantly when the deluge valve is actuated and high pressure is present.
6. An upstream port on the deluge valve allows connecting a drain valve (available upon request).
7. Pressure gauges [g1, g2, g3] allow visual inspection of the upstream, pilot-line and downstream pressures.
8. Pressure switches [p1, p2] (optional), may be connected to the control chamber, to the deluge valve's downstream port or to the pressurized pilot-line, allowing an electric indication of opening of the deluge valve or decreasing air pressure.

## **DELUGE PRESSURE REDUCING VALVE MODEL 68P-DE\PORV\PR-MR**

### **Commissioning Procedure (refer to fig. 2 – System P&ID)**

The following procedures should be carried out as written, in addition to relevant NFPA demands or other local applicable regulations.

It is recommended that the installation and adjustment be performed by qualified personnel.

**Note:**

Ball valves b3-b5 are part of the water motor alarm trim which is optional. Ignore any reference to them if they do not exist.

1. Verify the following:
  - a. Valves [b1, b5, b6] are open (their handles are parallel to the pipe axis).
  - b. Valves [b2, b3, b4, b7, j] are closed (their handles are perpendicular to the pipe axis).
2. Commissioning:

If water pressure is not present at the deluge valve, assume the deluge valve is not shut:

  - a. Close the deluge valve's downstream isolation valve and open the downstream drain valve.
  - b. Slowly introduce water into the pipeline, reaching the deluge valve.  
Note: At this point large volumes of water may flow out the downstream drain valve.
  - c. Press the DMR's [m] knob and wait for the valve to close, indicated by water flow stopping in the downstream drain valve.
  - d. Once water stops flowing downstream, close the deluge valve's downstream drain valve and the open the downstream isolation valve.

If water pressure is present at the deluge valve:

- a. Close the deluge valve's downstream isolation valve and open the downstream drain valve.
- b. Press the DMR's [m] knob and wait for the valve to close, indicated by water flow stopping in the downstream drain valve.
- c. Once water stops flowing downstream, close the deluge valve's downstream drain valve and the open the downstream isolation valve.

Ensure having the designed working pressure upstream of the deluge valve and in the pilot-line.

The deluge valve is now in "standby" mode.

3. Optional manual emergency actuation commissioning test:
  - a. Open the manual emergency actuation valve [b2]. The deluge valve will open.
  - b. To re-close the deluge valve refer to "General Description".

## **DELUGE PRESSURE REDUCING VALVE MODEL 68P-DE\PORV\PR-MR**

### **Commissioning Procedure (refer to fig. 2 – System P&ID)**

4. Automatic actuation commissioning (following completion of items 1-2 above) :
  - a. Close the deluge valve's downstream isolation valve and open the downstream drain valve.
  - b. Actuation: open the test ball valve [b7] to simulate pneumatic actuation (rupture of a sprinkler). The deluge valve will open instantly.  
Close the test ball valve [b7]
  - c. Close the deluge valve's downstream drain valve and then open the downstream isolation valve.
  - d. To close the deluge valve refer to "General Description".
5. Pneumatic and pressure reducing set-point change – if required:
  - a. Close the downstream isolation valve and open the downstream drain valve.
  - b. Actuate the valve (item 4 above).  
Note: large volumes of water may flow out the downstream drain valve.

#### Pneumatic set-point change

The 66-2UL [k] relay is factory set to trip when pneumatic pressure drops below 2bar.  
To change the set-point:

- Unlock the 66-2UL [k] relay's bolt using the lock nut.
- Gradually close the adjustment bolt of the 66-2UL relay [k] until water starts leaking from the downstream drain valve.
- Open the bolt until leaking stops.
- Lock the bolt using the lock nut.

#### Pressure reducing set-point change

The deluge valve's downstream pressure is factory set according to the client's specification.

If not specified – it is factory set to 4bars.

- Unlock the pressure reducing pilot valve's [n] bolt using the lock nut.
  - Close the downstream isolation valve and open the downstream drain valve to allow full flow through the deluge valve.
  - Actuate the valve.
  - Observe the downstream pressure gauge while gradually opening the adjustment bolt of the pressure reducing pilot valve [n] to lower the set point or gradually close the bolt to raise the set-point.
  - Once reaching the required downstream pressure, lock the bolt using the lock nut.
- c. Close the deluge valve (refer to "General Description").
  - d. Close the deluge valve's downstream drain valve and the open the downstream isolation valve.

## **DELUGE PRESSURE REDUCING VALVE MODEL 68P-DE\PORV\PR-MR**

### **Commissioning Procedure (refer to fig. 2 – System P&ID)**

6. Test the water motor alarm (if applicable):
  - a. Close ball valve [b5].
  - b. Open ball valve [b3]. The water motor alarm will sound.
  - c. Close ball valve [b3] and drain the water motor alarm pipeline through ball valve [b4]. Close this valve when water stops flowing.

## **DELUGE PRESSURE REDUCING VALVE MODEL 68P- DE\PORV\PR-MR**

### **Periodical Check-up and Maintenance**

In case of valve actuation due to a fire event, this procedure must be carried out immediately after the event has ended and the fire-suppression system is returned to its "ready" position. The owner of the valve is responsible for the setting, inspecting, routine testing and the maintenance of the valve as written, in compliance with NPFA directives or other local applicable regulations.

It is recommended that all tests and maintenance procedures be carried out by qualified personnel.

As some of the tests may sound an alarm, it is necessary to alert the local personnel and local fire-fighting authorities before the test is carried out.

1. Repeat the "Commissioning Procedure" steps above.
2. Inspect Y-Type strainer [c]: close ball valve [b1], open the cover of the Y-Type strainer, remove the screen element, clean and reassemble.
3. Open ball valve [b1].

## DELUGE PRESSURE REDUCING VALVE MODEL 68P-DE\PORV\PR-MR

Design Data (Flanged & grooved end connections)

### Head loss chart

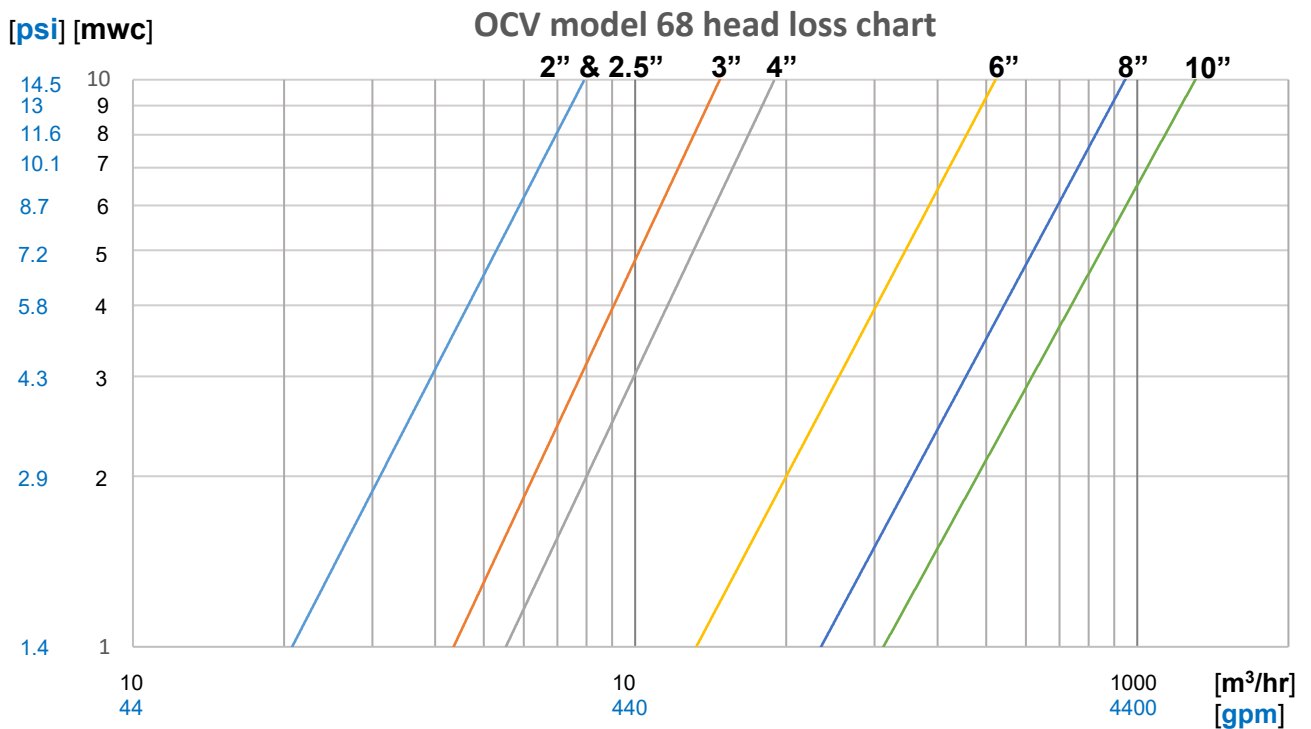

### Hydraulic characteristics

Valve Size		50 (2")	65 (2.5")	80 (3")	100 (4")	150 (6")	200 (8")	250 (10")
<b>K<sub>v</sub></b>	m³/hr @ 1	78	78	120	200	550	800	1300
<b>C<sub>v</sub></b>	gpm @ 1 psi	91	91	140	234	643	935	1519
<b>K Factor</b>	-	1.7	1.7	3.7	4.2	2.8	4.2	3.9
<b>Equivalent Pipe Length @ C<sub>HW</sub> = 120</b>	meters	3.7	13.3	16.4	18.9	20.9	42.5	51.2
	feet	12	44	54	62	69	139	168
<b>Control Chamber Displacement Volume</b>	Liters	0.18	0.18	0.3	0.5	2	4.8	6.2
	Gallons	0.05	0.05	0.08	0.13	0.53	1.27	1.64

- 66-2UL relay pressure adjustment range: 0.6-9 bar \ 9-130 psi.

## **DELUGE PRESSURE REDUCING VALVE MODEL 68P-DE\PORV\PR-MR**

### **Design Data (Flanged & grooved end connections)**

#### **Regulating pressures**

- Maximal adjustable outlet pressure: 22 bar \ 320 psi
- Minimal adjustable outlet pressure: 2 bar \ 30 psi

#### **Note:**

- The minimal head loss across the valve reaches 1.2 bar (18 psi) at a maximal flow velocity of 5.5 m/s (18 ft/s).
- The valve maintains the preset downstream pressure at the adjusted value, unless upstream pressure drops below the designated downstream pressure + 1.2 bar (18 psi).
- Downstream pressure may exceed the adjusted value by 0.5 bar (7 psi) when the flow through the valve is stopped gradually.
- The minimal upstream pressure shall be at least 1.7 bar (25 psi) for setting purposes with the flow at ½ the maximal flow.

#### **Maximal flow rates:**

Valve Size - Inch (mm)	Flow Rate [m <sup>3</sup> /hr]	Flow Rate [gpm]
2" & 2.5"(50 & 65)	40	170
3" (80)	100	440
4" (100)	155	680
6" (150)	350	1540
8" (200)	622	2736
10" (250)	971	4274

\* Calculated at an industry accepted flow velocity of 5.5 m/s

## DELUGE PRESSURE REDUCING VALVE MODEL 68P-DE/PORV/PR-MR

### Operation Modes

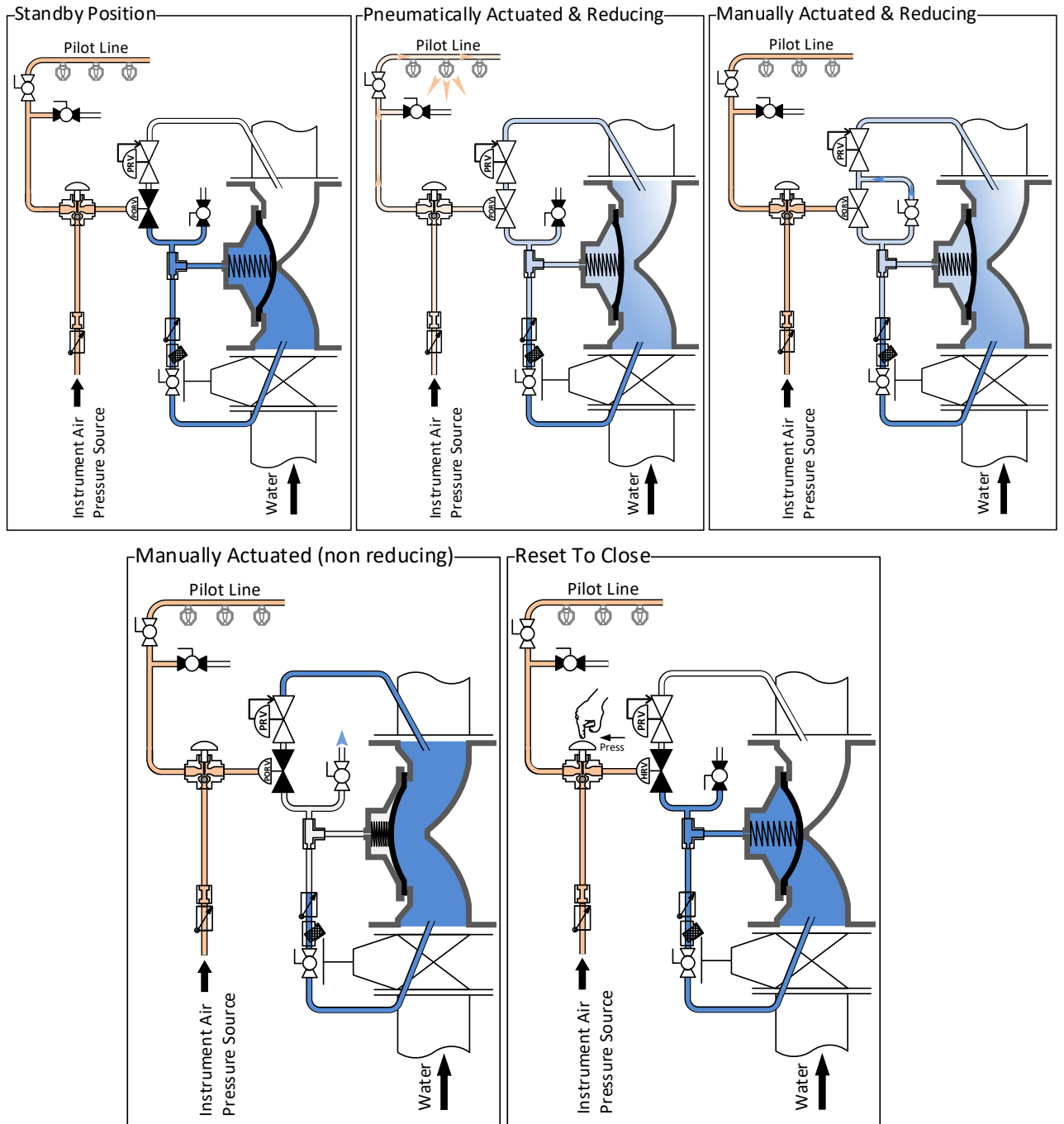



## DELUGE VALVE MODEL 68P-DE\ PORV\PR-MR

### Basic Valve Dimensions

Valve Size		50 (2")		65 (2.5")		80 (3")		100 (4")		150 (6")		200 (8")		250 (10")		300 (12")		
		mm	inch	mm	inch	mm	inch	mm	inch	mm	inch	mm	inch	mm	inch	mm	inch	
Dimensions	68	L	228	8 <sup>7</sup> / <sub>8</sub>	233	9 <sup>3</sup> / <sub>16</sub>	310	12 <sup>3</sup> / <sub>16</sub>	356	14	436	17 <sup>1</sup> / <sub>8</sub>	530	20 <sup>13</sup> / <sub>16</sub>	636	25	N/A	N/A
		H	169	6 <sup>5</sup> / <sub>8</sub>	185	7 <sup>5</sup> / <sub>16</sub>	237	9 <sup>5</sup> / <sub>16</sub>	263	10 <sup>5</sup> / <sub>16</sub>	378	14 <sup>13</sup> / <sub>16</sub>	481	18 <sup>7</sup> / <sub>8</sub>	546	21 <sup>1</sup> / <sub>2</sub>	N/A	N/A
		R	85	3 <sup>5</sup> / <sub>16</sub>	92.5	3 <sup>11</sup> / <sub>16</sub>	105	4 <sup>1</sup> / <sub>8</sub>	120	4 <sup>11</sup> / <sub>16</sub>	150	5 <sup>7</sup> / <sub>8</sub>	180	7	215	8 <sup>3</sup> / <sub>8</sub>	N/A	N/A
		W*	175	6 <sup>7</sup> / <sub>8</sub>	185	7 <sup>5</sup> / <sub>16</sub>	200	7 <sup>13</sup> / <sub>16</sub>	260	10 <sup>3</sup> / <sub>16</sub>	320	12 <sup>5</sup> / <sub>8</sub>	400	15 <sup>11</sup> / <sub>16</sub>	495	19 <sup>3</sup> / <sub>8</sub>	N/A	N/A
	Weight kg/lbs	10 / 22	14.5 / 32	30 / 66.1	38 / 83.8	75 / 165.3	123 / 271	190 / 419	N/A	N/A								
68 Grooved	L	243	9 <sup>5</sup> / <sub>8</sub>	253	10	336	13 <sup>3</sup> / <sub>16</sub>	380	15	440	17 <sup>5</sup> / <sub>16</sub>	556	21 <sup>7</sup> / <sub>8</sub>	N/A	N/A	N/A	N/A	
	H	143	5 <sup>5</sup> / <sub>8</sub>	143	5 <sup>5</sup> / <sub>8</sub>	220	8 <sup>11</sup> / <sub>16</sub>	229	9	337	13 <sup>5</sup> / <sub>16</sub>	433	17	N/A	N/A	N/A	N/A	
	R	55	2 <sup>3</sup> / <sub>16</sub>	55	2 <sup>3</sup> / <sub>16</sub>	77	3	86.5	3 <sup>3</sup> / <sub>8</sub>	114	4 <sup>1</sup> / <sub>2</sub>	139	5 <sup>1</sup> / <sub>2</sub>	N/A	N/A	N/A	N/A	
	W*	172	6 <sup>13</sup> / <sub>16</sub>	172	6 <sup>13</sup> / <sub>16</sub>	236	9 <sup>5</sup> / <sub>16</sub>	261	10 <sup>5</sup> / <sub>16</sub>	326	12 <sup>13</sup> / <sub>16</sub>	400	15 <sup>11</sup> / <sub>16</sub>	N/A	N/A	N/A	N/A	
	Weight kg/lbs	6.2 / 13.7	6.4 / 14	14.5 / 32	21 / 46.3	38.5 / 85	66 / 145.5	N/A	N/A									

\* Valve width

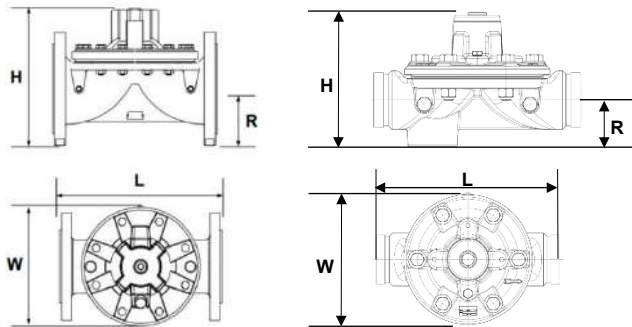

**DELUGE PRESSURE REDUCING VALVE MODEL 68P-DE\POR\PR-MR**  
**Trim Dimensions (Flanged & grooved end connections)**

Valve size		2" (50)		2.5"(65)		3"(80)		4"(100)		6"(150)		8"(200)		10"(250)	
		Inch	mm	Inch	mm	Inch	mm	Inch	mm	Inch	mm	Inch	mm	Inch	mm
Dimension	A	9 1/8	230	9 3/16	233	12 3/16	310	14	356	17 3/16	436	20 7/8	530	25 1/8	636
	B	12 5/16	311	12 5/16	311	12 5/16	311	12 5/16	311	12 5/16	311	12 5/16	311	12 1/2	318
	C	8 5/8	218	8 5/8	218	8 5/8	218	8 5/8	218	8 5/8	218	10 3/8	265	12 1/2	318
	D	10 3/8	264	10 3/8	264	10 7/8	277	11 5/16	288	12 5/8	320	13 5/16	338	14 5/16	364
	E	6 11/16	170	6 11/16	170	7 3/16	183	7 5/8	194	8 7/8	226	9 5/8	244	10 5/8	270
	R	3 5/16	85	3 5/8	92.5	4 1/8	105	4 11/16	120	5 7/8	150	7 1/8	180	8 1/2	215
	G	10 5/8	268	10 5/8	268	12 13/16	324	12 13/16	324	16 1/8	409	18 5/8	472	19 1/2	494

\* Dimensions are approximate

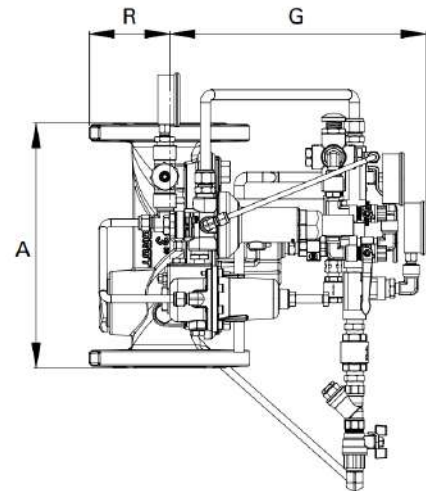
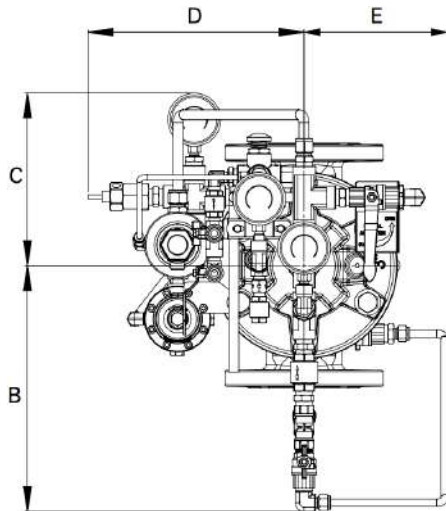

## Safety Instructions:

### PLEASE NOTE

- Before using this product, read and understand the instructions.
- All procedures must be carried out by qualified personnel.
- Make sure that all applicable safety precautions have been taken in addition to these instructions.
- Read this manual along with all the provided data.
- Save these instructions for future reference.

### Before disassembly of any accessory or component:

- All internal pressures must be relieved and all media drained from the system in accordance with all applicable procedures.
- Pressure must be 0 (zero) bar/psi.

### Before Installation:

- **Flush the lines upstream of the pressure reducing valve. If anti-corrosion, anti-freeze or any other type of additives are used, please consult the documentation or OCV FP division concerning potential damage to the valve and its components.**
- Remove all external and internal packaging along with any temporary protective material.
- Carefully inspect the valve to ensure that no damage has occurred in transit or during subsequent handling.
- Ensure that the valve is the correct type and size and that the identification markings show that the material and pressure/temperature rating is suitable for the required service conditions.
- Read the installation instructions carefully and follow them.
- Ensure that the valve is lifted safely into position without damaging the valve.
- Ensure that the valve is installed so that it can be safely operated and maintained without putting any people at risk.
- Make sure that a firm footing is provided for the person installing the valve with adequate space around the valve to meet operating and maintenance requirements.
- Ensure that there is adequate lighting for valve installation.
- The valve can be installed in any position, but flow direction should match the engraved arrow on the bonnet.

*Failure to follow the instructions set forth in this publication could result in property damage, personal injury, or death from hazards that may be associated with this type of equipment.*