



68-DE\EL\HRV-MR

Electrically and Hydraulically Actuated
Anti-Columning, Manual-Reset
Deluge Valve

IOM

Installation • **O**peration • **M**aintenance



Installation, Operation & Maintenance

This document specifies the operating concept of OCV deluge valve model 68-X-DE\EL\HRV-MR (X refers to valve size in Inch), UL listed when trimmed per the following technical data sheet

Please review the safety instructions at the end of this document prior to commissioning the valve for use

DELUGE VALVE MODEL 68-DE\EL\HRV-MR General Description

OCV's deluge and pre-action valve model 68-X-DE\EL\HRV-MR is a globe/weir-type hydraulic valve, actuated automatically or manually. The valve is mounted on the upstream side of a fire-suppression sprinkler system, preventing flow into the system in its "ready" position.



Operating pressures

- Pressure rating up to 25 bar \ 375 psi
- Minimum system pressure 1.5 bar \ 22 psi

UL listed working pressures

- 2" - 10": 25 bar \ 375 psi

Available end connections

- Flanged: 2" – 10" (Including 2.5")
- Grooved: 2" – 8" (Including 2.5")

Available body & cover and trim materials

Body & Cover	Valve Fitting	Valve Tubing	Diaphragm
Ductile Iron A536*	Brass*	Copper*	Neoprene*
CF8M/ASTM A-316	SST316	Cu-Ni 90/10	NR
Ni-Al-Bronze ASTM B148 gr.C95800	SST304 ASTM A 351	SST316	EPDM
Cast Steel ASTM A 216 WCB	Super Duplex 2507	Super Duplex 2507	NBR
	Aluminum-Bronze		
	MONEL®		

* Standard material

DELUGE VALVE MODEL 68-DE\EL\HRV-MR General Description

Deluge valve actuation:

1. The deluge valve is actuated when pressure in the pilot-line drops to a preset value or when a normally open solenoid valve is energized, (or the coil of a continuously energized ED 100% normally closed solenoid is de-energized for SIL 3-4 rated systems).
2. In case of failure of the automatic actuation system, manual emergency actuation is possible.
3. Automatic or manual emergency actuation causes the DMR [m] to seal shut the connection between the control chamber and the upstream pressure source. Reopening the connection between the deluge valve's control chamber and the upstream pressure source can only be accomplished by pressing the DMR's [m] knob.

Manual emergency actuation:

1. The manual emergency actuation valve [b2] may be located inside a metal box or over a plate. If in a box – first lift the cover - and turn the handle as shown on the plaque in the box.

Closing the deluge valve is possible only after:

1. Closing the upstream isolation valve.
2. De-energizing the solenoid.
3. Restoring pressure in the pilot-line.
4. Closing the manual emergency actuation ball valve [b2].
5. Manual-reset by holding the DMR's [m] knob until the deluge valve has closed.

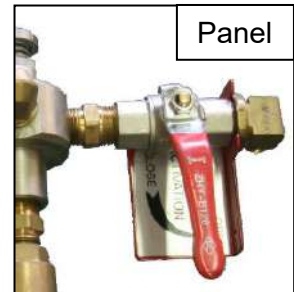

DELUGE VALVE MODEL 68-DE\EL\HRV-MR

Pre-Installation Recommendations (refer to fig. 2 – System P&ID)

1. The valve is factory trimmed for both vertical and horizontal installation - out of the box, requiring no changes or tooling.
2. The valve may be installed either vertically (with the upstream positioned at the bottom) or horizontally.
3. Sufficient space for maintenance should be left around the deluge valve.
4. Manual isolating valves (gate type, butterfly type or equivalent - not supplied) should be assembled upstream and downstream of the deluge valve for maintenance purposes.
5. A drain facility for the water drained during the valve's test & working procedures should be prepared.

Fig. 1- General layout

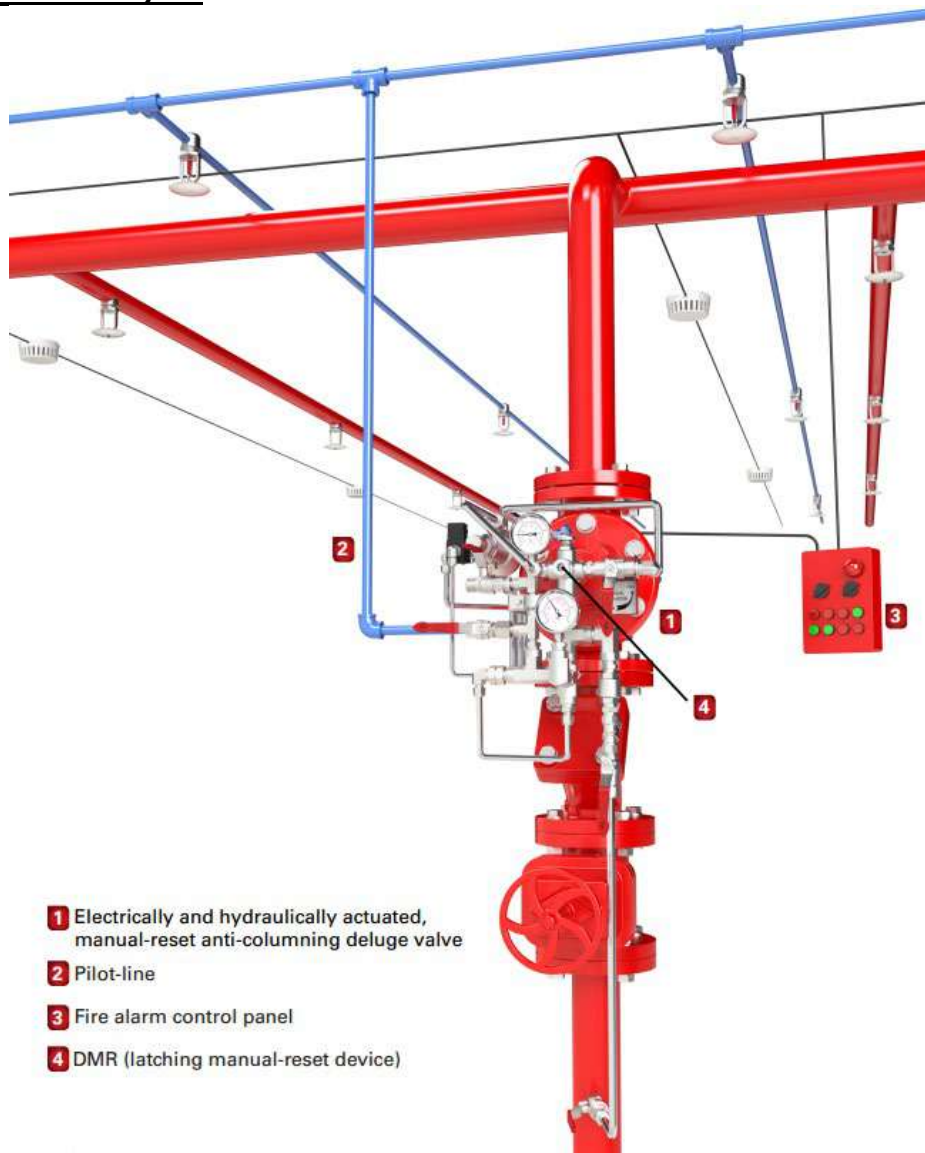

DELUGE VALVE MODEL 68-DE\EL\HRV-MR

Installation (refer to fig. 2 – System P&ID)

1. The deluge valve should be positioned in such a way that allows easy access to the emergency manual actuation valve [b2].
2. The priming control trim's ball valve [b1] should be connected to the main supply pipe upstream of the inlet isolating valve.
3. Connect the water motor alarm (optional) to the alarm trim's isolation ball valve [b5].
4. Connect the solenoid valve [a] to the fire alarm control panel.
5. Connect the pilot-line to the pilot-line's isolation ball valve [b6].
6. The drain valve [j], the outlet pipes of the 66-2UL relay [k], the pilot-line's test ball valve [b7] and the emergency manual valve [b2], should be drained.

DELUGE VALVE MODEL 68-DE\EL\HRV-MR

Fig. 2- System P&ID

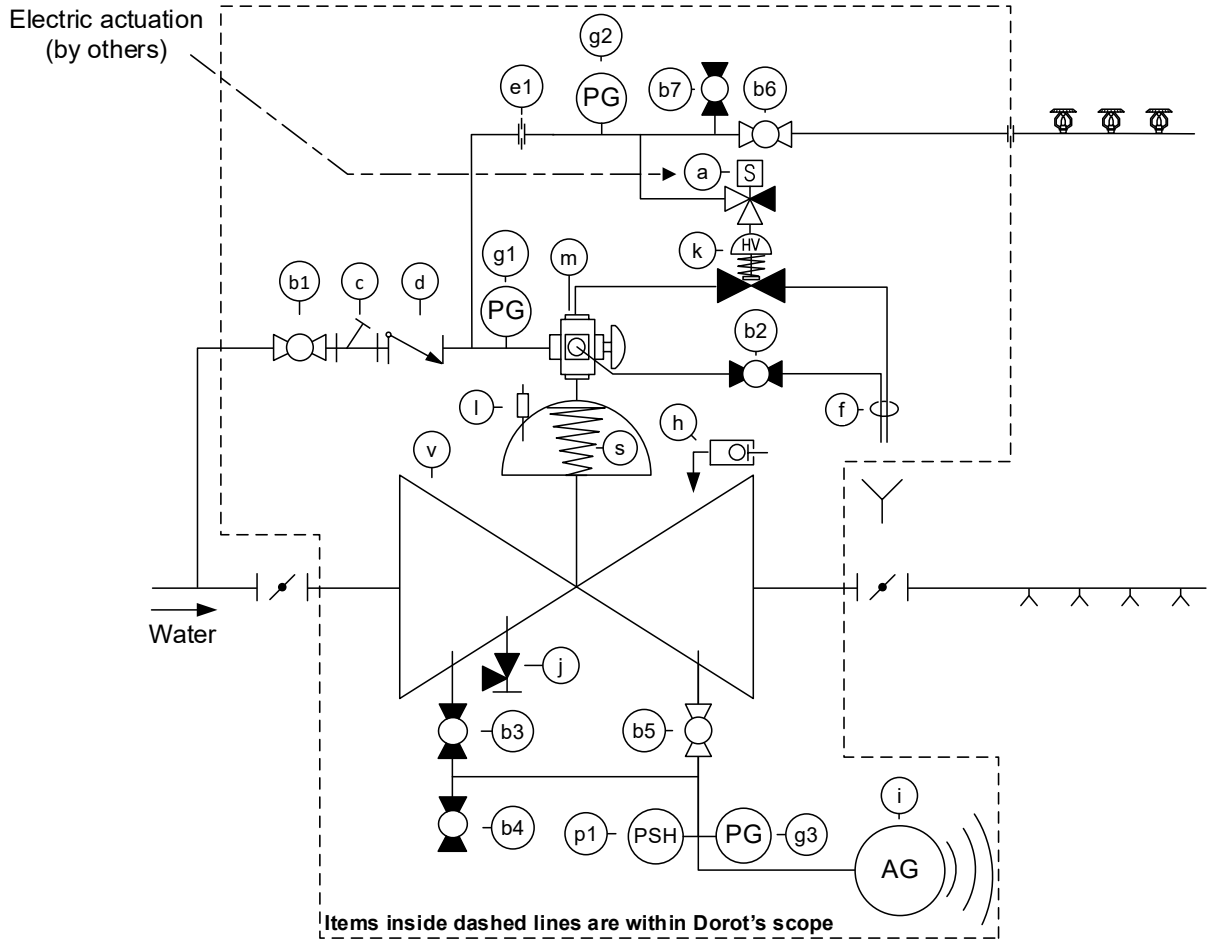

Integral System items	
Item #	Description
v	Hydraulic valve
a	3/2 N.O. solenoid
b1	Priming line ball valve
b2	Emergency manual activation valve
c	Y-Type strainer
d	Check valve
e	DMR (latching manual-reset device)
e1	Restrictor
f	1/2" tube
g1, g2	Pressure gauge
h	Drip valve
k	66-2UL-relay

Optional System items	
Item #	Description
b3	Alarm trim - test ball valve
b4	Alarm trim - drain\purge ball valve
b5	Alarm trim - isolation ball valve
g3	Pressure gauge
i	Water motor alarm
j	Drain valve
l	Indicator Rod
p1	Pressure switch high - water
s	Spring

DELUGE VALVE MODEL 68-DE\EL\HRV-MR

Control Trim Connection (refer to fig. 2 – System P&ID)

1. The deluge valve's control chamber is connected to a pressure source upstream of the inlet isolating valve.

NOTE: if using an external pressure source, it should be at a pressure equal or higher than the maximal upstream pressure.

2. The upstream control trim includes the following items:
 - Priming control trim's ball valve [b1].
 - Y-Type strainer [c].
 - Check valve [d].
 - DMR (latching manual-reset device) [m].
3. The 66-2UL relay [k] is connected to the 3/2 way N.O. solenoid [a].
The 66-2UL relay [k] has two positions:
 - 'Closed' - prevents draining of the deluge valve's control chamber.
 - 'Open' - allows draining of the control chamber, thus opening the deluge valve.
4. The 3/2 way N.O. solenoid [a] is connected to the 66-2UL relay [k] and to the fire alarm control panel. When energized (via the fire alarm control panel), the 3/2 way N.O. solenoid [a], releases the pressure from the control chamber, through the 66-2UL relay [k], instantly opening the deluge valve.
5. A water motor alarm [i] may be connected to the deluge valve via an optional alarm trim. The alarm trim consists of:
 - Ball valve [b5], which is normally-open.
 - Ball valve [b3], which is normally-closed and allows testing the alarm without opening the deluge valve.
 - Ball valve [b4], which is normally-closed and allows draining the alarm trim and purging it from corrosive fluids if necessary.
5. A low-pressure drip valve (relief valve) [h], is mounted on a downstream port of the deluge valve, as a safety device against faulty sealing of the deluge valve, which may be caused by foreign objects or unclean water.
The drip valve allows small quantities of water to be drained from the system but shuts instantly when the deluge valve is actuated and high pressure is present.
6. An upstream port on the deluge valve allows connecting a drain valve [j] (available upon request).

DELUGE VALVE MODEL 68-DE\EL\HRV-MR**Control Trim Connection (refer to fig. 2 – System P&ID)**

7. Pressure gauges [g1, g2, g3] allow visual inspection of the upstream, pilot-line and downstream pressures.
8. A pressure switch [p1] (optional), may be connected to the control chamber or to the deluge valve's downstream port, allowing an electric indication of opening of the deluge valve.

DELUGE VALVE MODEL 68-DE\EL\HRV-MR

Commissioning Procedure (refer to fig. 2 – System P&ID)

The following procedures should be carried out as written, in addition to relevant NFPA demands or other local applicable regulations.

It is recommended that the installation and adjustment be performed by qualified personnel.

Note:

Ball valves b3-b5 are part of the water motor alarm trim which is optional.
Ignore any reference to them if they do not exist.

Verify the following:

1. The isolating valve upstream of the deluge valve is closed.
2. Valves [b1, b5, b6] are open (their handles are parallel to the pipe axis).
3. Valves [b2, b3, b4, b7, j] are closed (their handles are perpendicular to the pipe axis).

Commissioning:

1. Ensure minimal designed pressure, upstream of the deluge valve.
2. Open the drain valve downstream of the deluge valve.
3. Slightly open the upstream isolating valve, allowing the pipe section upstream of the valve to fill until no air is released through the drain valve; press the DMR's [m] knob and wait for the valve to close, indicated by water flow stopping in the downstream drain valve.
4. Ensure the designed pressure in the pilot-line.
5. Close the drain valve downstream of the deluge valve.
6. Fully open both isolating valves.
7. The deluge valve is now set for service.

Optional manual emergency actuation commissioning test:

1. Open the manual emergency actuation valve [b2]. The deluge valve will open.
2. To close the deluge valve refer to "General Description".

DELUGE VALVE MODEL 68-DE\EL\HRV-MR

Commissioning Procedure (refer to fig. 2 – System P&ID)

Automatic actuation commissioning:

1. Energize the solenoid [a]. The deluge valve will open instantly.
2. To close the deluge valve refer to “General Description”.
3. Gradually open the pilot-line – test ball valve [b7] to simulate the rupture of sprinklers. The deluge valve will open.
4. The 66-2UL [k] relay is factory set at 2 bars. If on-site calibration is required - gradually close the adjustment bolt of the 66-2UL relay [k] until water start leaking from its drain pipe. Open the bolt until leaking stops.
If on-site calibration is not required – disregard this stage.
5. Gradually close the pilot-line – test ball valve [b7].
6. To close the deluge valve refer to “General Description”.

Test the water motor alarm (if applicable):

1. Close ball valve [b5].
2. Open ball valve [b3]. The water motor alarm will sound.
3. Close ball valve [b3] and drain the water motor alarm pipeline through ball valve [b4]. Close this valve when water stops flowing.

Reset the deluge valve:

1. To recommission the deluge valve refer to “Commissioning”.

DELUGE VALVE MODEL 68-DE\EL\HRV-MR **Periodical Check-up and Maintenance**

In case of valve actuation due to a fire event, this procedure must be carried out immediately after the event has ended and the fire-suppression system is returned to its "ready" position. The owner of the valve is responsible for the setting, inspecting, routine testing and the maintenance of the valve as written, in compliance with NPFA directives or other local applicable regulations.

It is recommended that all tests and maintenance procedures be carried out by qualified personnel.

As some of the tests may sound an alarm, it is necessary to alert the local personnel and local fire-fighting authorities before the test is carried out.

1. Repeat the "Commissioning Procedure" steps above.
2. Inspect Y-Type strainer [c]: close ball valve [b1], open the cover of the Y-Type strainer, remove the screen element, clean and reassemble.
3. Open ball valve [b1].

DELUGE VALVE MODEL 68-DE\EL\HRV-MR

Design Data (Flanged & grooved end connections)

Head loss chart

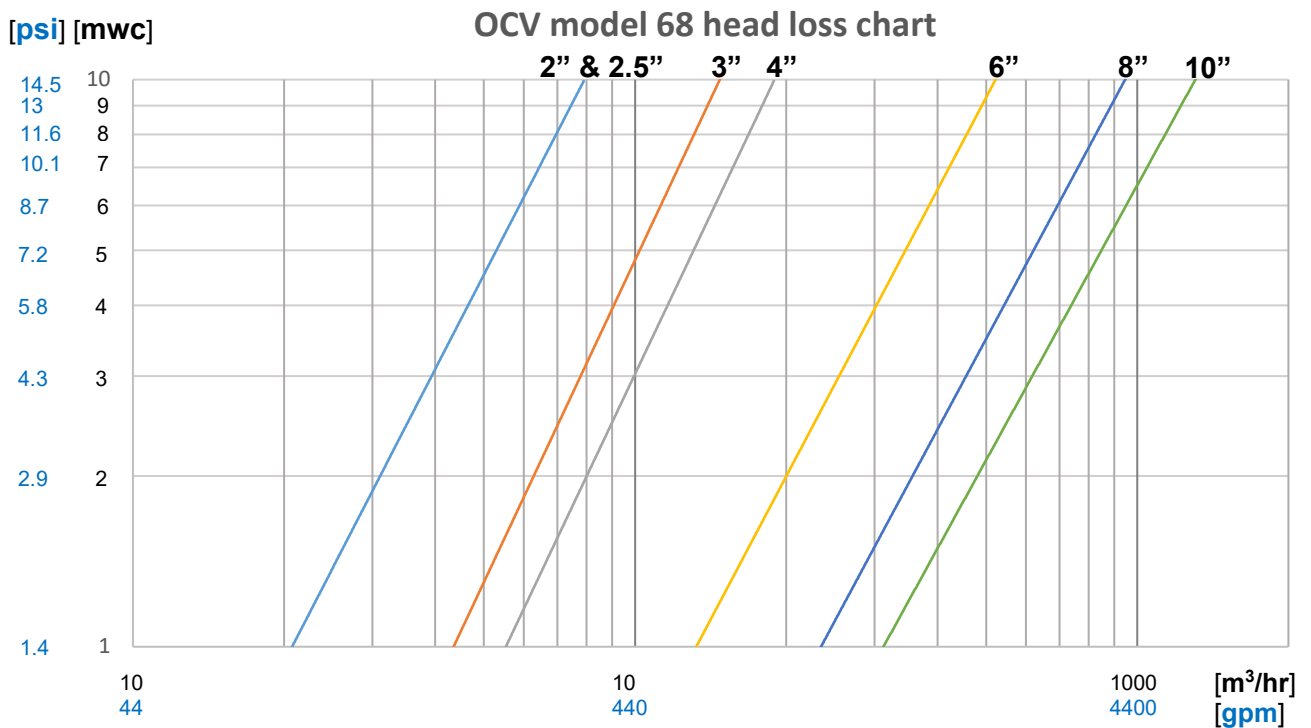

Hydraulic characteristics

Valve Size		50 (2")	65 (2.5")	80 (3")	100 (4")	150 (6")	200 (8")	250 (10")
K_v	m ³ /hr @ 1	78	78	120	200	550	800	1300
C_v	gpm @ 1 psi	91	91	140	234	643	935	1519
K Factor	-	1.7	1.7	3.7	4.2	2.8	4.2	3.9
Equivalent Pipe Length @ C_{HW} = 120	meters	3.7	13.3	16.4	18.9	20.9	42.5	51.2
	feet	12	44	54	62	69	139	168
Control Chamber Displacement Volume	Liters	0.18	0.18	0.3	0.5	2	4.8	6.2
	Gallons	0.05	0.05	0.08	0.13	0.53	1.27	1.64

- 66-2UL relay pressure adjustment range: 0.6-9 bar \ 9-130 psi.

DELUGE VALVE MODEL 68-DE\EL\HRV-MR

Operation Modes

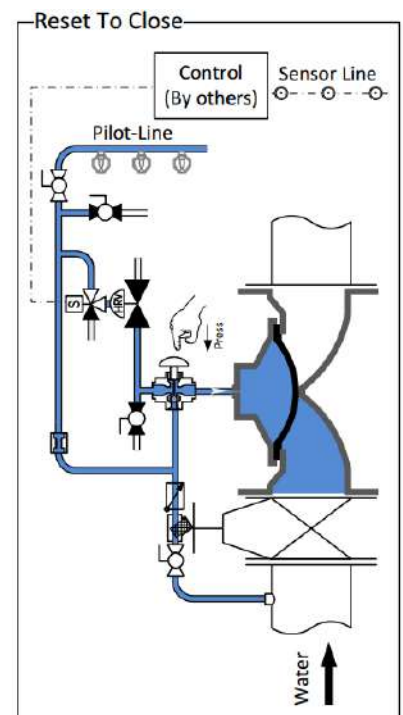
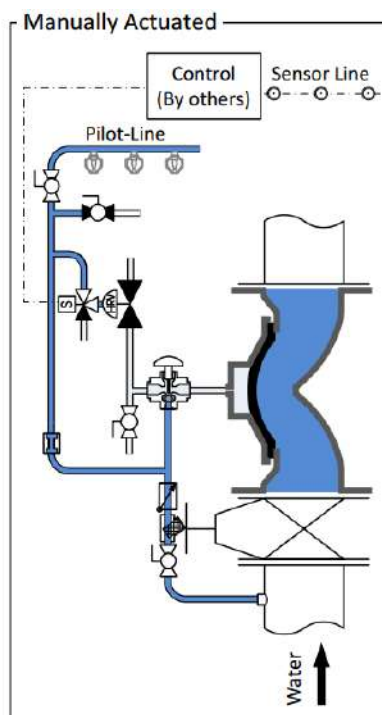
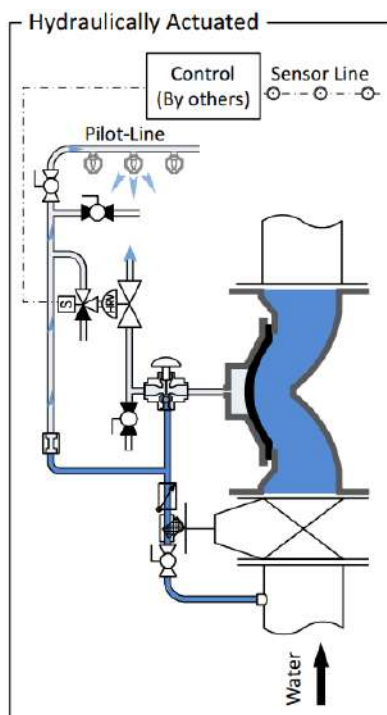
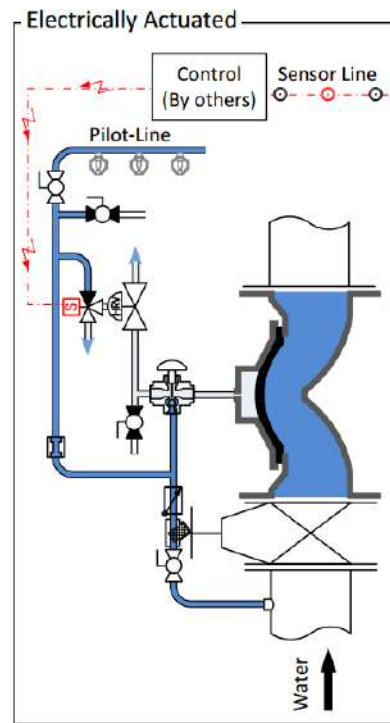
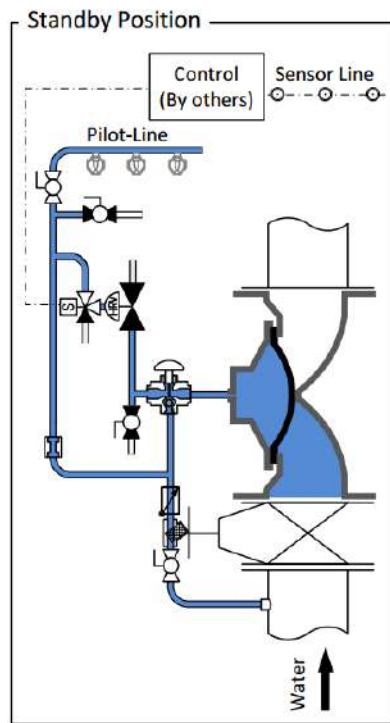

DELUGE VALVE MODEL 68-DE\HRV-MR

Basic Valve Dimensions

Valve Size		50 (2")		65 (2.5")		80 (3")		100 (4")		150 (6")		200 (8")		250 (10")		300 (12")		
		mm	inch	mm	inch	mm	inch	mm	inch	mm	inch	mm	inch	mm	inch	mm	inch	
Dimensions	68	L	228	8 ⁷ / ₈	233	9 ³ / ₁₆	310	12 ³ / ₁₆	356	14	436	17 ¹ / ₈	530	20 ¹³ / ₁₆	636	25	N/A	N/A
		H	169	6 ⁵ / ₈	185	7 ⁵ / ₁₆	237	9 ⁵ / ₁₆	263	10 ⁵ / ₁₆	378	14 ¹³ / ₁₆	481	18 ⁷ / ₈	546	21 ¹ / ₂	N/A	N/A
		R	85	3 ⁵ / ₁₆	92.5	3 ¹¹ / ₁₆	105	4 ¹ / ₈	120	4 ¹¹ / ₁₆	150	5 ⁷ / ₈	180	7	215	8 ³ / ₈	N/A	N/A
		W*	175	6 ⁷ / ₈	185	7 ⁵ / ₁₆	200	7 ¹³ / ₁₆	260	10 ³ / ₁₆	320	12 ⁵ / ₈	400	15 ¹¹ / ₁₆	495	19 ³ / ₈	N/A	N/A
	Weight kg/lbs	10 / 22		14.5 / 32		30 / 66.1		38 / 83.8		75 / 165.3		123 / 271		190 / 419		N/A	N/A	
68 Grooved	L	243	9 ⁵ / ₈	253	10	336	13 ³ / ₁₆	380	15	440	17 ⁵ / ₁₆	556	21 ⁷ / ₈	N/A	N/A	N/A	N/A	
	H	143	5 ⁵ / ₈	143	5 ⁵ / ₈	220	8 ¹¹ / ₁₆	229	9	337	13 ⁵ / ₁₆	433	17	N/A	N/A	N/A	N/A	
	R	55	2 ³ / ₁₆	55	2 ³ / ₁₆	77	3	86.5	3 ³ / ₈	114	4 ¹ / ₂	139	5 ¹ / ₂	N/A	N/A	N/A	N/A	
	W*	172	6 ¹³ / ₁₆	172	6 ¹³ / ₁₆	236	9 ⁵ / ₁₆	261	10 ⁵ / ₁₆	326	12 ¹³ / ₁₆	400	15 ¹¹ / ₁₆	N/A	N/A	N/A	N/A	
	Weight kg/lbs	6.2 / 13.7		6.4 / 14		14.5 / 32		21 / 46.3		38.5 / 85		66 / 145.5		N/A	N/A	N/A	N/A	

* Valve width

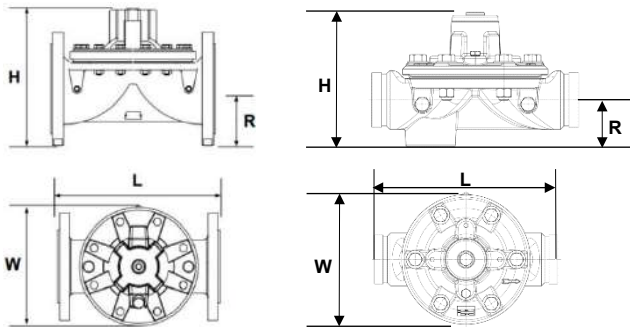

DELUGE VALVE MODEL 68-DE\EL\HRV-MR
Trim Dimensions (Flanged & grooved end connections)

Valve size		2" & 2.5"(50 & 65)		3"(80)		4"(100)		6"(150)		8"(200)		10"(250)	
		Inch	mm	Inch	mm	Inch	mm	Inch	mm	Inch	mm	Inch	mm
Dimension	A	10	254	12 ³ / ₁₆	310	14	355	17 ³ / ₈	443	20 ⁷ / ₈	530	25	635
	B	6 ⁵ / ₈	168	7 ⁷ / ₈	200	9 ³ / ₈	238	12 ¹ / ₈	306	14 ³ / ₁₆	360	16 ⁷ / ₈	430
	C	4 ³ / ₈	111	5 ¹¹ / ₁₆	144	6 ³ / ₁₆	158	7 ⁵ / ₁₆	187	8 ⁷ / ₈	227	10 ¹³ / ₁₆	276
	D	10	253	10	253	10	253	10	253	10	253	10	253
	E	9 ¹³ / ₁₆	249	12 ³ / ₈	315	12 ³ / ₁₆	311	15 ¹ / ₂	394	16 ⁵ / ₁₆	414	17 ³ / ₁₆	437
	F	12 ⁷ / ₈	328	12 ⁷ / ₈	328	12 ⁷ / ₈	328	12 ⁷ / ₈	328	12 ⁷ / ₈	328	12 ⁷ / ₈	328

* Dimensions are approximate

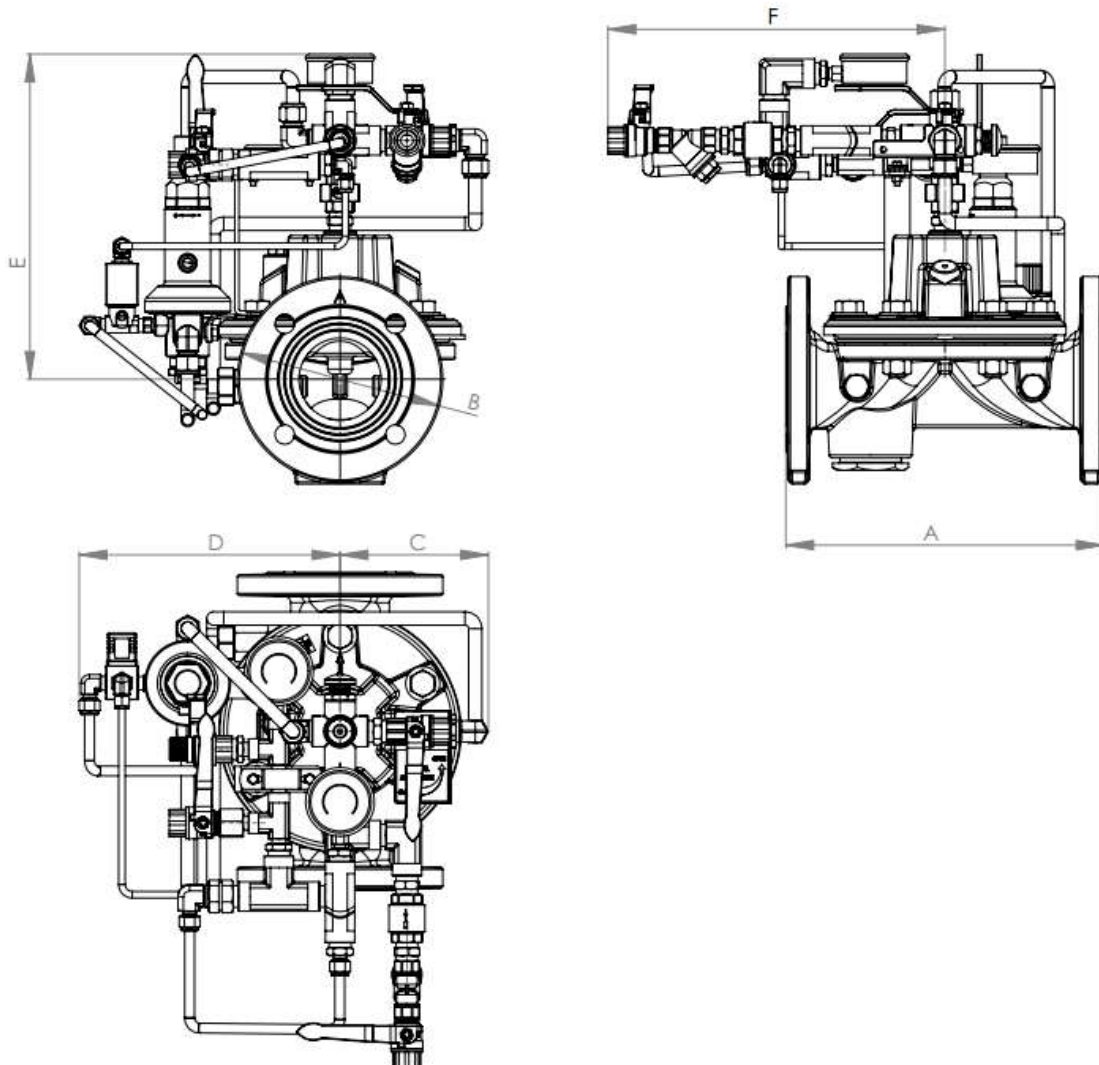

Safety Instructions:

PLEASE NOTE

- Before using this product, read and understand the instructions.
- All procedures must be carried out by qualified personnel.
- Make sure that all applicable safety precautions have been taken in addition to these instructions.
- Read this manual along with all the provided data.
- Save these instructions for future reference.

Before disassembly of any accessory or component:

- All internal pressures must be relieved and all media drained from the system in accordance with all applicable procedures.
- Pressure must be 0 (zero) bar/psi.

Before Installation:

- **Flush the lines upstream of the pressure reducing valve. If anti-corrosion, anti-freeze or any other type of additives are used, please consult the documentation or OCV FP division concerning potential damage to the valve and its components.**
- Remove all external and internal packaging along with any temporary protective material.
- Carefully inspect the valve to ensure that no damage has occurred in transit or during subsequent handling.
- Ensure that the valve is the correct type and size and that the identification markings show that the material and pressure/temperature rating is suitable for the required service conditions.
- Read the installation instructions carefully and follow them.
- Ensure that the valve is lifted safely into position without damaging the valve.
- Ensure that the valve is installed so that it can be safely operated and maintained without putting any people at risk.
- Make sure that a firm footing is provided for the person installing the valve with adequate space around the valve to meet operating and maintenance requirements.
- Ensure that there is adequate lighting for valve installation.
- The valve can be installed in any position, but flow direction should match the engraved arrow on the bonnet.

Failure to follow the instructions set forth in this publication could result in property damage, personal injury, or death from hazards that may be associated with this type of equipment.