

# Operating Manual

**Model: 116-4FC**

**Size: "**

**Serial #:**

**Sales Order:**

7400 East 42nd Place  
Tulsa, Oklahoma  
74145-4744 USA

**phone:** 918-627-1942  
888-628-8258

**fax:** 918-622-8916

**email:** [sales@controlvalves.com](mailto:sales@controlvalves.com)

**website:** [www.controlvalves.com](http://www.controlvalves.com)



**Global** performance. **Personal** touch.

# electrically operated deluge valve (energize to open)

installation, operating  
and  
maintenance instructions

## model 116-4FC

SK7000 12-17-98

### GENERAL DESCRIPTION

The OCV Model 116-4FC solenoid control valve, also described as a **deluge valve**, is designed to open or close in response to an electrical signal. It is **UL Listed**, and consists of the following components:

1. **Model 65FC Basic Valve**, a hydraulically-operated, diaphragm-actuated, globe valve with an elastomer-on-metal seal.
2. **Model 452 Solenoid Pilot** a three-way, electrically-operated valve.
3. **Model 330P or Model 3600S Three-Way Auxiliary Pilot**, a three-way, hydraulically-operated valve.
4. **Model 159 Y-Strainer** or **Model 123 Inline Strainer**. The strainer protects the pilot system from solid contaminants in the line fluid.
5. Two **Model 141-4 Ball Valves**. See schematic diagram for normal positions of the ball valves.
6. **Model 155 Visual Indicator Assembly**. Useful for indication of valve position at a glance.

### DRAIN PORT

A large 2" NPTF drain port is provided underneath the main valve body for quick drainage of inlet (supply) piping on sizes 4" thru 10". 1 1/4" NPTF is provided on the 3" valve.

**THEORY OF OPERATION** (refer to schematic diagram):

Operation of the 116-4FC is extremely simple. Energizing the coil of the solenoid pilot connects port "1" (supply) to port "2" (common), which pressurizes the diaphragm chamber of the three-way auxiliary pilot. This pilot shifts to relieve pressure from the diaphragm chamber of the main valve. Thus, the main valve opens.

Conversely, deenergizing the coil of the solenoid pilot connects port "2" (common) and port "3" (exhaust), which vents the diaphragm chamber of the three-way auxiliary pilot. The pilot shifts to route full inlet pressure to the diaphragm chamber of the main valve. Thus, the main valve closes fully.

### INSTALLATION

The 116-4FC is furnished fully factory-assembled and ready for installation at the appropriate point in the system. The user is referred to the Basic Valve section of this manual for full installation details.

Once the main valve is installed, the solenoid pilot is wired into the control system. This is a simple two-wire hookup.

### STARTUP AND ADJUSTMENT

The following procedures should be followed in the order presented in order to effect an initial startup of the 116-4FC. **If difficulty in performance is experienced, contact the factory at 1-800-331-4113 or 1-888-OCV-VALV (1-888-628-8258) for a toll free discussion with an engineer, member of the sales staff, or for the name of the closest factory representative for your area.**

1. Make sure the coil of the solenoid pilot is deenergized.
2. Start the pump, or otherwise start the system flowing. The main valve will at this time be **fully closed**.
3. **(CONTROL CIRCUIT AIR PURGE)** Carefully, only slightly, open the manual override ball valve (5B) on the main valve bonnet until fluid begins to discharge. When only clear fluid (no air bubbles) is discharging, reclose the ball valve. **Be careful because opening the manual override ball valve too much may allow the valve to open.** If opening the valve does not present a system problem at this stage, cycling the valve open and closed a few times via the manual override ball valve, or the solenoid pilot will serve the same purpose.
4. Energize the solenoid pilot, if have not done already. Observe that the main valve opens.
5. Deenergize the solenoid pilot and observe that the valve closes.

## MAINTENANCE

Due to the simplicity of design of the 116-4FC, required maintenance is minimal. However, the following checks, periodically performed, can do much to keep the valve operating properly and efficiently.

1. Check for chipped or peeling paint. Touch up as required.
2. Check for leaks at fittings and around flanges and connections. Tighten as required.
3. Check for frayed or loose electrical connections.
4. If the valve is equipped with a Y-strainer, check the screen for buildup of solid material. Clean as required. This point is most important, as a clogged strainer can keep the valve from closing. On new installations, it is recommended that the strainer be checked every day or two until experience dictates a greater or lesser interval. Strainer maintenance is covered in detail on a special page later in this manual.

## TROUBLESHOOTING

In the event of malfunction of the 116-4FC, the following guide should enable the technician to isolate the specific cause of the problem and take the appropriate corrective action.

### A. MAIN VALVE FAILS TO OPEN:

**NOTE: THIS VALVE IS EQUIPPED WITH A MANUAL OVERRIDE FEATURE 5B. OPENING IT WILL BYPASS THE OTHER COMPONENTS IN THE PILOT SYSTEM AND WILL OPEN THE MAIN VALVE BY VENTING THE BONNET TO ATMOSPHERE.**

1. Valve closed upstream or downstream of the 116-4FC. Open as required.
2. Solenoid not energized. Check electrical system.
3. Solenoid pilot stuck closed or coil burned out. See Solenoid Valve section of this manual.
4. Stem of three-way auxiliary pilot binding or seat deteriorated. Disassemble pilot and determine cause. See 330P or 3600S section of this manual.
5. Stem of main valve binding. Disassemble valve and determine cause. See the Model 65FC Basic Valve section of this manual.

### B. MAIN VALVE FAILS TO CLOSE:

1. Upstream pilot system ball valve closed. Open as required.
2. Solenoid not deenergized. Check electrical system.
3. Strainer clogged. Clean as required.
4. Solenoid pilot stuck open. See Solenoid Valve section of this manual.
5. Three-way auxiliary pilot diaphragm ruptured, stem binding or seat deteriorated. Disassemble pilot and determine cause. See 330P or 3600S section of this manual.
6. Close inlet ball valve 5A and loosen a pipe plug in the main valve bonnet. A **continuous dis-**

charge of fluid from the loosened plug indicates that the main valve diaphragm is ruptured. Replace diaphragm. See the Model 65FC Basic valve section of this manual.

7. Main valve stem binding or object in valve. Disassemble valve and determine cause. See Basic Valve section of this manual.

# MODEL 116-4FC

RON  
12-2-98  
REV A  
12-8-98

## DELUGE SOLENOID CONTROL VALVE (Energize to Open)

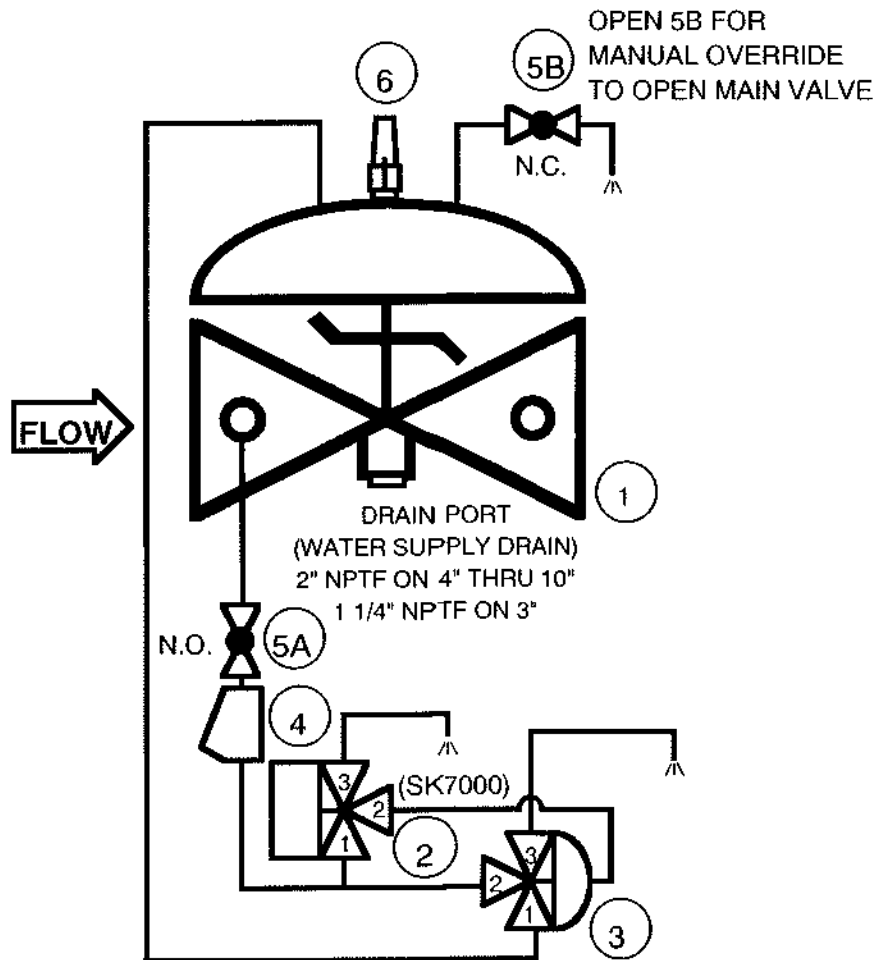

NOTE: AS AN OPTION, THE PILOT SYSTEM MAY BE VENTED TO DISCHARGE

ITEM	PART NO.	QTY	DESCRIPTION
1	65FC	1	BASIC VALVE ASSEMBLY (UL LISTED 3" THRU 10")
2	452	1	THREE-WAY SOLENOID PILOT
3	3600S or 330P	1	ACCELERATOR PILOT
4	159	1	Y-STRAINER
5	141-4	2	BALL VALVE
6	155	1	VISUAL INDICATOR

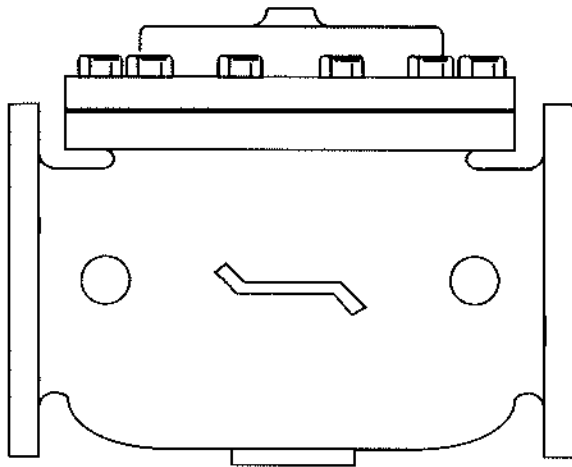

## installation, operating, and maintenance instructions

# model 65FC

Rev. 9-10-98

## basic *deluge* control valve

### GENERAL DESCRIPTION

The OCV Model 65FC is a hydraulically-operated, diaphragm-actuated valve. It is available in the globe configuration and is **UL Listed** for **Deluge service** in sizes 3" thru 10". The diaphragm is nylon-fabric bonded with synthetic rubber and forms a sealed chamber in the upper portion of the valve, separating operating pressure from line pressure. An elastomeric seat disc forms a tight seal with the valve seat when pressure is applied above the diaphragm. A 1 1/4" NPTF opening is provided for rapid drainage of the main water supply on the 3" valve. A 2" NPTF opening is provided on the 4" thru 10" valves.

### FUNCTIONAL DESCRIPTION

Because the Series 65FC is a hydraulically operated valve, it requires a minimum line pressure of approximately 5 psig in order to function. The valve functions on a simple principle of pressure differential. The line pressure at the inlet of the valve is bypassed through the pilot control piping to the diaphragm chamber of the valve. This pressure, together with the valve spring, works against the pressure under the valve seat. Because the effective area of the diaphragm is greater than that of the seat, the valve is held tightly closed. As the controlling pilot(s) allow the pressure to bleed off the diaphragm chamber, the two opposing pressures begin to balance and the valve will begin to open. The valve can be used to perform a simple on-off function, or with the proper pilot system, a modulating, or regulating function.

In cases where the line fluid is unusually dirty, or is otherwise unsuitable for operating the valve, an independent operating pressure source may be employed. The pressure available from such a source must be equal to, or greater than, line pressure.

### INSTALLATION

In order to insure safe, accurate and efficient operation of the OCV control valve, the following list of checkpoints and procedures should be followed when installing the valve.

1. Make a careful visual inspection of the valve to insure that there has been no damage to the external piping, fittings or controls. Check that all fittings are tight.
2. Thoroughly flush all interconnecting piping of chips, scale and foreign matter prior to mounting the valve.
3. Install the valve in the line according to the flow arrow on the inlet flange. The arrow should point downstream.
4. Allow sufficient room around the valve for ease of adjustment and maintenance service.

In addition, it is highly recommended that:

1. When allowed, isolation valves (eg., gate or butterfly) be installed on the inlet and discharge

sides of the valve to facilitate isolating the valve for maintenance.

2. Pressure gauges be installed at the inlet and outlet sides of the valve to provide monitoring of the valve during initial start-up and during operation. The body side ports, if unused by the pilot system, provide a convenient connection for the gauges.
3. All valves larger than 6" be installed horizontally, i.e., with the bonnet pointed up, for ease of adjustment and maintenance servicing.

**MAINTENANCE**

The OCV control valve requires no lubrication and a minimum of maintenance. However, a periodic inspection should be established to determine how the fluid being handled is affecting the efficiency of the valve. In a water system, for example, the fluid velocity as well as the substances occurring in natural waters, such as dissolved minerals and suspended particles, vary in every installation. The effect of these actions or substances must be determined by inspection. It is recommended that an annual inspection, which includes examination of the valve interior, be conducted. Particular attention should be paid to the elastomeric parts, i.e., the diaphragm and seat disc. Any obviously worn parts should be replaced.

**REPAIR PROCEDURES**

In the event of malfunction of the OCV control valve, troubleshooting should be conducted according to the procedures outlined for the specific model of valve. Then, if those steps indicate a problem with the main valve, this section will outline the procedures necessary to correct the problem. **If difficulty in performance is experienced, contact the factory at 1-800-331-4113 or 1-888-OCV-VALV (1-888-628-8258) for a toll free discussion with an engineer, member of the sales staff, or for the name of the closest factory representative for your area.**

Problems with the main valve can be classed in three basic categories:

1. VALVE FAILS TO OPEN
  - a. Diaphragm damaged\* - See Procedure A
  - b. Stem binding - See Procedure B
2. VALVE FAILS TO CLOSE
  - a. Diaphragm damaged\* - See Procedure A
  - b. Stem binding - See Procedure B
  - c. Object lodged in valve - See Procedure B
3. VALVE OPENS AND CLOSES BUT LEAKS WHEN CLOSED
  - a. Seat disc damaged - See Procedure C
  - b. Seat ring damaged - See Procedure D

*\*A diaphragm failure can prevent the valve from either opening or closing, depending on the flow direction. Most water service valves flow "under the seat", in which case a diaphragm failure will keep the valve from closing.*

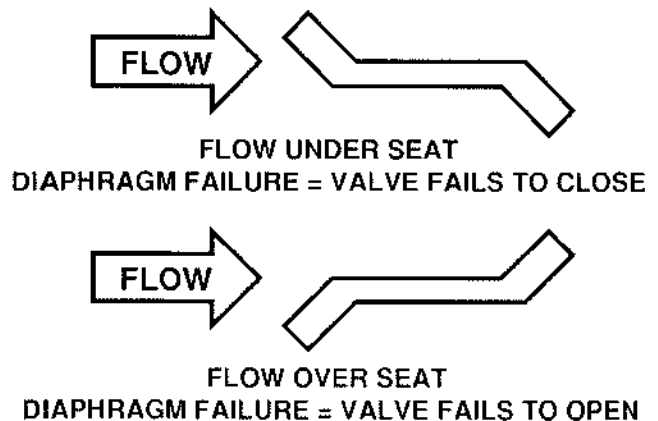

***PROCEDURE A : DIAPHRAGM REPLACEMENT***

1. Isolate the valve from the system by closing upstream and downstream block valves.
2. Loosen one of the tubing connections on the

bonnet. Allow any residual pressure to bleed off.

3. Remove all tubing connected at the bonnet.
4. Remove the bonnet nuts.
5. Remove the bonnet. If the bonnet sticks in place, it may be loosened by rapping sharply around its edge with a *rubber-headed* mallet. *NOTE: 8" and larger valves are equipped with eye bolts through which a chain can be fastened to aid in lifting the bonnet.*
6. Remove the spring.
7. Remove the diaphragm plate capscrews and the diaphragm plate.
8. Remove the old diaphragm.
9. Making sure the dowel pin holes are in the proper location, place the new diaphragm over the studs and press down until it is flat against the body and spool.
10. Replace the diaphragm plate and the diaphragm plate capscrews.
11. Tighten all diaphragm plate capscrews snugly.
12. Replace the spring.
13. Replace the bonnet and reinstall the bonnet nuts.
14. Tighten the bonnet nuts snugly using a criss-cross tightening pattern.
15. Reinstall the control tubing.
16. Reopen the upstream and downstream block valves.
17. Before placing the valve back in service, perform the air bleed procedure described in the first section of this manual.

#### PROCEDURE B: CORRECTION OF BINDING STEM

1. Perform Steps 1 thru 6 of Procedure A, above.
2. Remove the spool assembly from the valve. *NOTE: On smaller valves, this can be accomplished simply by grasping the stem and pulling upward. Valves 6" and larger have the top of the stem threaded to accept an eyebolt to aid in lifting the spool out of the body. 6" thru 10" valves are threaded 3/8-16.*
3. Carefully examine both ends of the stem for deep scratches, scoring or buildup of mineral deposits. Polish the stem if necessary using a fine grade of emery cloth.
4. Similarly, examine and polish the upper bushing (in the bonnet) and the lower guide (in the seat ring).
5. Reinstall the spool assembly.
6. Reassemble the valve, following Steps 12 thru 17 in Procedure A.

#### PROCEDURE C: SEAT DISC REPLACEMENT

1. Perform Steps 1 and 2 of Procedure B, above.
2. With the spool assembly removed from the body, remove the seat retainer screws.
3. Slide the seat retainer off the lower end of the stem.
4. Remove the seat disc from its groove in the spool. *NOTE: The seat disc may fit quite tightly in the groove. If necessary, it may be pried out using a thin-bladed screwdriver or similar tool.*
5. Install the new seat disc in the groove.
6. Reinstall the seat retainer and tighten the seat retainer screws.
7. Reassemble the valve, following Steps 5 and 6 of Procedure B.



**PROCEDURE D: SEAT RING REPLACEMENT**

*NOTE: It is rare for a seat ring to require replacement. Minor nicks and scratches in the seating surface can usually be smoothed out with emery cloth.*

1. Perform Steps 1 and 2 of Procedure B, above.
2. If you are working on a 4" or smaller valve, follow Steps 3 thru 9, below.
3. If you are working on a 6" or larger valve, follow Steps 10 thru 16, below.
4. Seat rings in valves 4" and smaller are threaded into the valve body. To remove, you will need a special seat ring tool. You may fabricate one using standard pipe as shown in the sketch below, or one may be purchased from OCV.
5. Using the seat ring tool, unthread the seat ring from the body.
6. Remove the old o-ring from the counterbore in the body.
7. Install the new o-ring in the counterbore.
8. Using the seat ring tool, install the new seat ring.
9. Reassemble the valve, following Steps 5 & 6 of Procedure B.
10. Seat rings in valves 6" and larger are bolted into the body with socket head capscrews. In addition you will note that the seat ring is equipped with additional threaded holes that may be used for "jacking" the seat ring out of the body.
11. Remove the socket head capscrews.
12. Remove the old seat ring from the body by temporarily installing two or more of the capscrews in the "jacking" holes.
13. Install a new o-ring in the groove of the new seat ring. Lubricate the o-ring and outer seat ring wall with Vaseline® or similar lubricant.
14. Install the new seat ring in the body, making sure that the capscrew holes line up.
15. Replace and tighten all the capscrews.
16. Reassemble the valve, following Steps 5 and 6 of Procedure B.

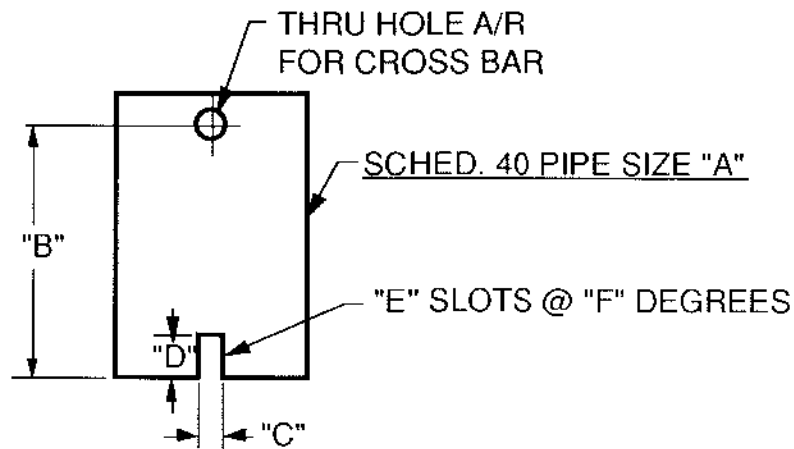

VALVE SIZE	"A" PIPE SIZE	"B" MIN. LENGTH	"C" SLOT WIDTH	"D" SLOT DEPTH	"E" NO. OF SLOTS	"F" SLOT SPACING
1-1/4"	3/4"	6"	3/8"	3/8"	2	180°
1-1/2"	3/4"	6"	3/8"	3/8"	2	180°
2"	1-1/2"	7"	3/8"	3/8"	2	180°
2-1/2"	2"	8"	1/2"	1/2"	3	120°
3"	2-1/2"	9"	5/8"	5/8"	2	180°
4"	3"	10"	5/8"	5/8"	2	180°

REVISED 3-17-97

**INSTALLATION OF TRIM ASSEMBLY**

*A pneumatic air valve pilot Model 550 and Model 126 ejector assembly are shipped in a separate container when field assembly is required.*

1. Identify the size of the basic valve you have purchased.
2. Based on the size you have identified, choose the appropriate drawing located in this operating manual.
3. For valve sizes 3" through 6" use the drawing number 116FC3-6GA. Note 3/8" OD tubing and appropriate fittings are used on these sizes to attach the pilot system.
4. For valve sizes 8" and 10" use the drawing number 116FC8-10GA. Note 1/2" OD tubing and appropriate fittings are used on these sizes to attach the pilot system.
5. Attach the pilot system to the basic valve as shown in the appropriate drawings.
6. If further clarification is needed, contact the factory at 800-331-4113.

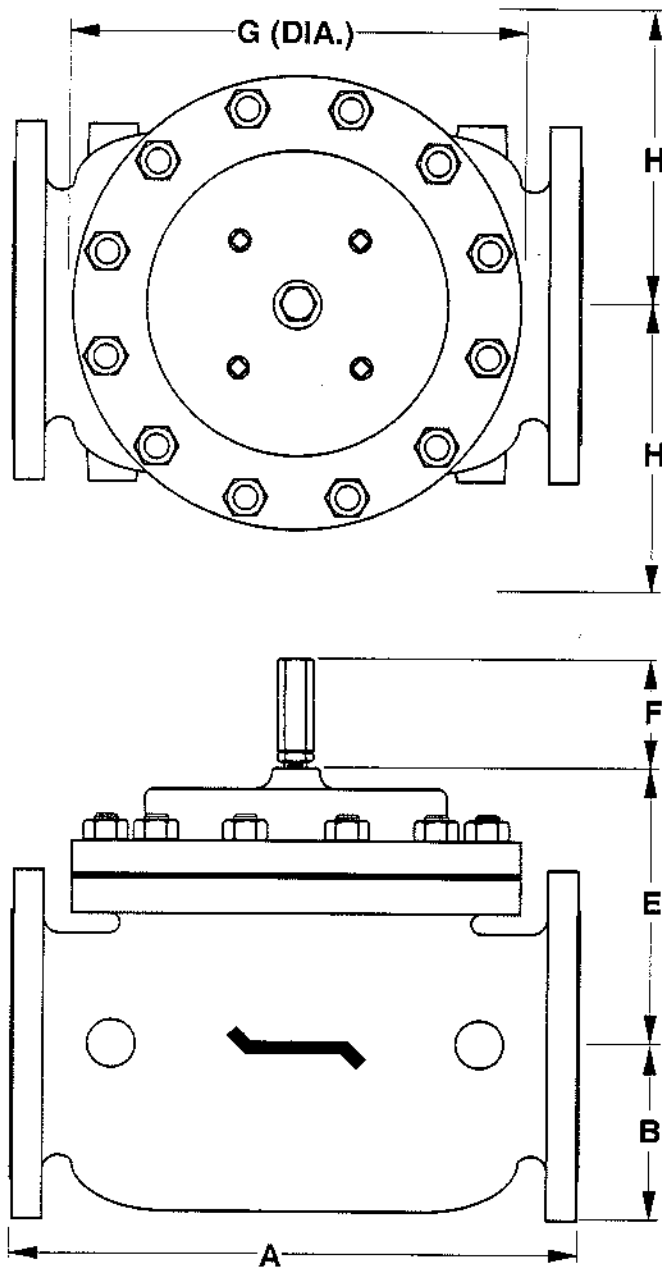

DIM	ANSI CLASS	VALVE SIZE												
		1 1/4	1 1/2	2	2 1/2	3	4	6	8	10	12	14	16	24
A	SE	8.75	8.75	9.88	10.50	13.00	-	-	-	-	-	-	-	-
	150	8.50	8.50	9.38	10.50	12.00	15.00	17.75	25.38	29.75	34.00	39.00	40.38	62.00
	300	8.75	8.75	9.88	11.12	12.75	15.62	18.62	26.38	31.12	35.50	40.50	42.00	63.75
B	SE	1.44	1.44	1.69	1.88	2.25	-	-	-	-	-	-	-	-
	150	2.31	2.50	3.00	3.50	3.75	4.50	5.50	6.75	8.00	9.50	10.62	11.75	16.00
	300	2.62	3.06	3.25	3.75	4.12	5.00	6.25	7.50	8.75	10.25	11.50	12.75	18.00
C	SE	4.38	4.38	4.75	6.00	6.50	-	-	-	-	-	-	-	-
	150	4.25	4.25	4.75	6.00	6.00	7.50	10.00	12.69	14.88	17.00	-	20.81	-
	300	4 3/8	4.38	5.00	6.38	6.38	7.81	10.50	13.19	15.56	17.75	-	21.62	-
D	SE	3.12	3.12	3.88	4.00	4.50	-	-	-	-	-	-	-	-
	150	3.00	3.00	3.88	4.00	4.00	5.50	6.00	8.00	11.38	11.00	-	15.69	-
	300	3.25	3.25	4.12	4.38	4.38	5.81	6.50	8.50	12.06	11.75	-	16.50	-
E	ALL	6.00	6.00	6.00	7.00	6.50	7.92	10.00	11.88	15.38	17.00	18.00	19.00	27.00
F	ALL	3.88	3.88	3.88	3.88	3.88	3.88	3.88	6.38	6.38	6.38	6.38	6.38	8.00
G	ALL	6.00	6.00	6.75	7.69	8.75	11.75	14.00	21.00	24.50	28.00	31.25	34.50	52.00
H	ALL	10.00	10.00	11.00	11.00	11.00	12.00	13.00	14.00	17.00	18.00	20.00	20.00	28.50

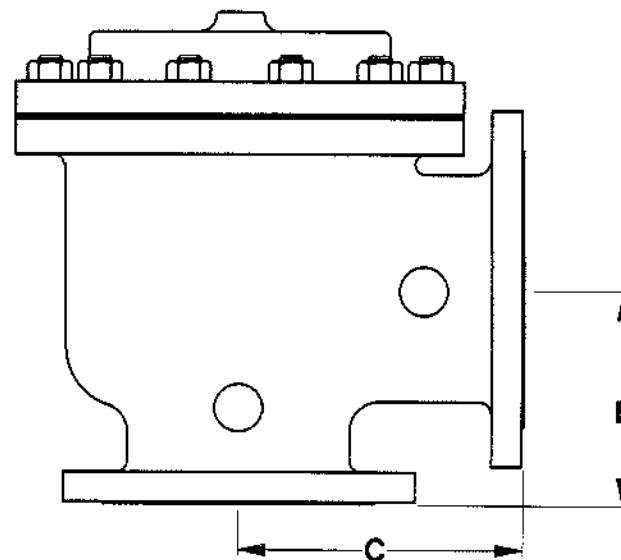

NOTE: 3" VALVE DIMENSIONS ARE FOR NEW MODEL 3100

4" VALVE DIMENSIONS ARE FOR NEW MODEL 4400

REV. A SDJ 6-6-02  
REV. B SDJ 2-3-03

TOLERANCES		OCV Control Valves TULSA, OKLAHOMA U.S.A.		
UNLESS NOTED		GENERAL VALVE DIMENSIONS		
FRACTIONAL ±1/64		SIZE	DRAWING NUMBER	REV.
DECIMAL ±.005		A	65D	B
MACH. FINISH 125/				
ANGULAR ±1/2°				
DRAWN BY	DATE			
SDJ	10-6-97			
CHKD. BY	DATE			

### THREE WAY VALVES

#### Direct Operated Valve Features

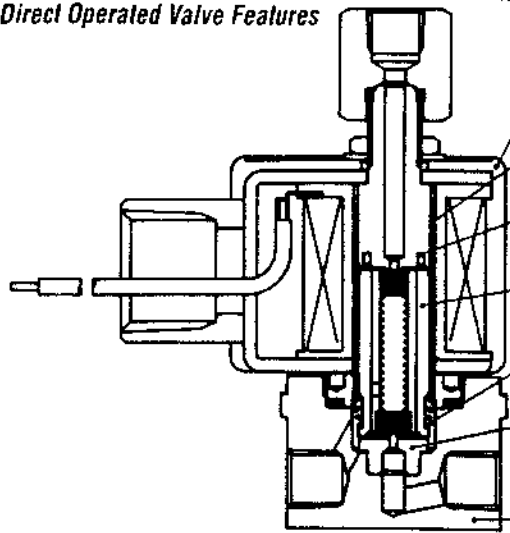

- Integrated Coils are fully encapsulated, eliminating the need for separate coils and enclosures. They are agency approved and available in a wide variety of types and terminations (1/2" Conduit shown).
- Corrosion resistant stainless steel sleeves are precision laser welded for strength and integrity.
- A shading ring in all sleeve assemblies ensures quiet operation and AC/DC compatibility from the same pressure vessel.
- Stainless steel plunger resists corrosion.
- Stainless steel plunger return springs provides positive plunger return, permitting valves to be mounted in any position.
- Pressed-in stainless steel orifices are highly finished. Their well-rounded surfaces will not cut the plunger seals, thus eliminating premature leakage while providing for long cycle life.
- Durable stainless steel or forged brass valve bodies.

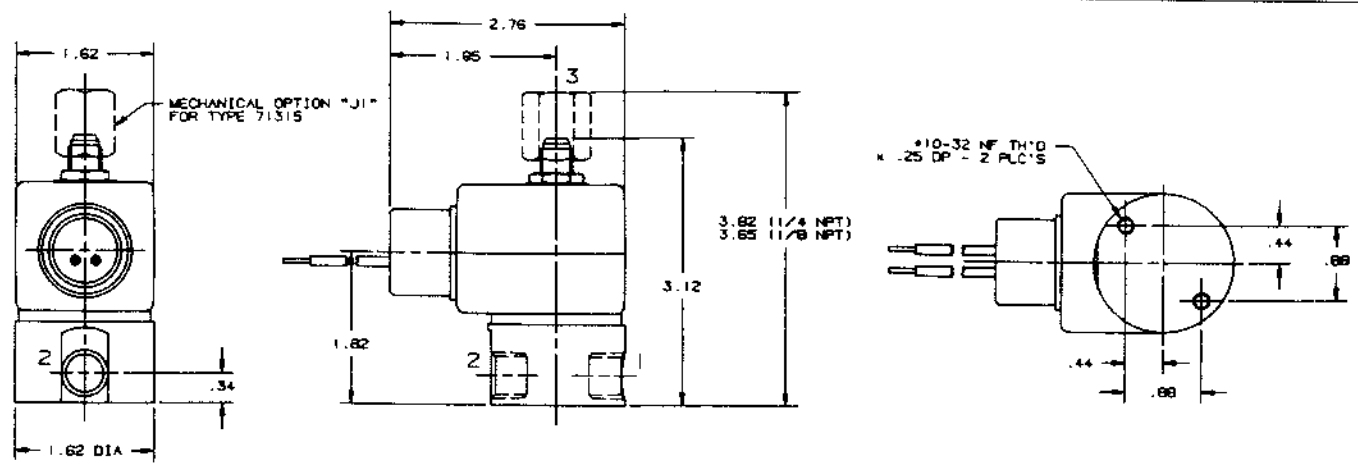

Construction Reference #31

**OCV CONTROL VALVES MODEL 452**  
 MULTIPURPOSE (UNIVERSAL)  
 3 WAY SOLENOID VALVE  
 BODY -  430F SS  BRASS  
 SEALS - NBR (BUNA-N)  
 SLEEVE TUBE - 303 OR 304 SS  
 PLUNGER - 430FR SS  
 STOP - 430FR SS  
 SPRINGS - 18-8 SS  
 SHADING RING - COPPER  
 PILOT ORIFICE - 303 SS

MAX OPERATING DIFFERENTIAL PRES = 400PSI  
 Cv FACTOR = .024  
 PIPE SIZE = 1/4"  
 VOLTAGE =  12DC  24DC  
 24AC  120AC  240AC  480AC  
 POWER CONSUMPTION = 10 WATTS  
 ELECTRICAL CONN = 1/2" CONDUIT  
 UL LISTED  
 NEMA 4, 4X, 7 & 9  
 LEAKAGE - BUBBLETIGHT  
 MAX AMBIENT TEMP = 65.5C (150 F)  
 MOUNTING POS = ANY

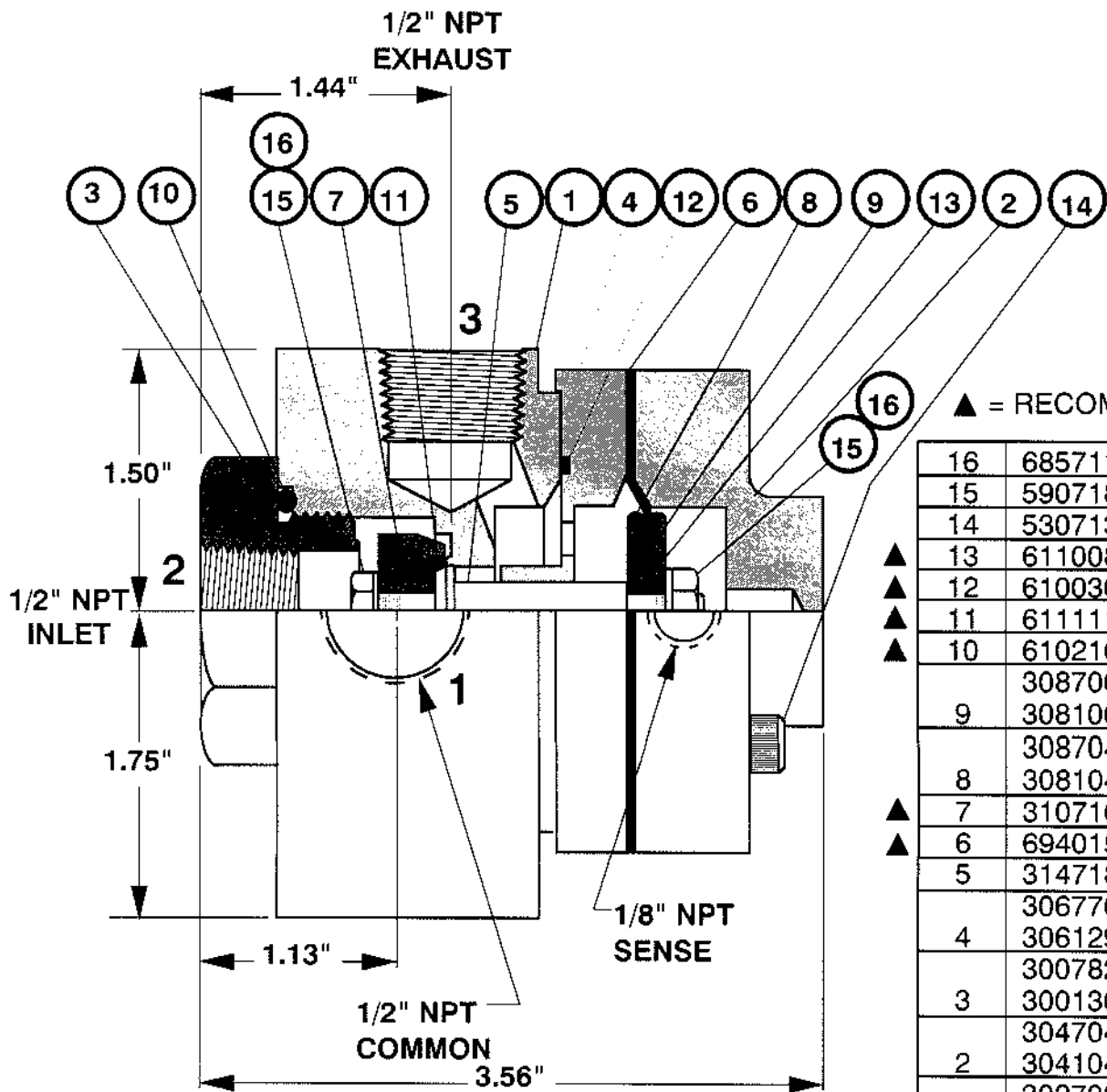

▲ = RECOMMENDED SPARE PARTS

16	685711	2	LOCKWASHER	STN. STEEL
15	590718	2	HEX NUT	STN. STEEL
14	530713	4	SKT. HD. CAPSCREW	STN. STEEL
▲ 13	611008	1	O-RING (610008 BUNA-N)	VITON
▲ 12	610030	1	O-RING (611030 VITON)	BUNA-N
▲ 11	611111	1	O-RING (610111 BUNA-N)	VITON
▲ 10	610216	1	O-RING (611216 VITON)	BUNA-N
9	308706			STN. STEEL
	308106	1	UPPER DIAPH. PLATE	BRASS
	308704			STN. STEEL
8	308104	1	LOWER DIAPH. PLATE	BRASS
▲ 7	310716	1	SEAT PLUG (310727 SS/VT)	SS/BUNA-N
▲ 6	694015	1	DIAPHRAGM (694115 VIT)	BUNA-N
5	314718	1	STEM	STN. STEEL
	306776			STN. STEEL
4	306129	1	GUIDE PLATE	BRASS
	300782			STN. STEEL
3	300130	1	ADAPTER	BRASS
	304704			STN. STEEL
2	304104	1	BONNET	BRONZE
	302700			STN. STEEL
1	302100	1	BODY	BRONZE
ITEM	PART NO	QTY	DESCRIPTION	MATERIAL

REVISIONS				REF DWG NO'S		MATERIAL		TOLERANCES	
CHG	E.C. NO.	DATE	BY					UNLESS NOTED FRACTIONAL ±1/64 DECIMAL ±.005 MACH. FINISH 125/ ANGULAR ±1/2° ✓	
						NO. REQ'D	DRAWN BY	DATE	
						SCALE	RON	12-17-98	
							CHKD. BY	DATE	

**OCV Control Valves**

**THREE-WAY PILOT**

SIZE	DRAWING NUMBER	REV.
<b>A</b>	<b>330P</b>	

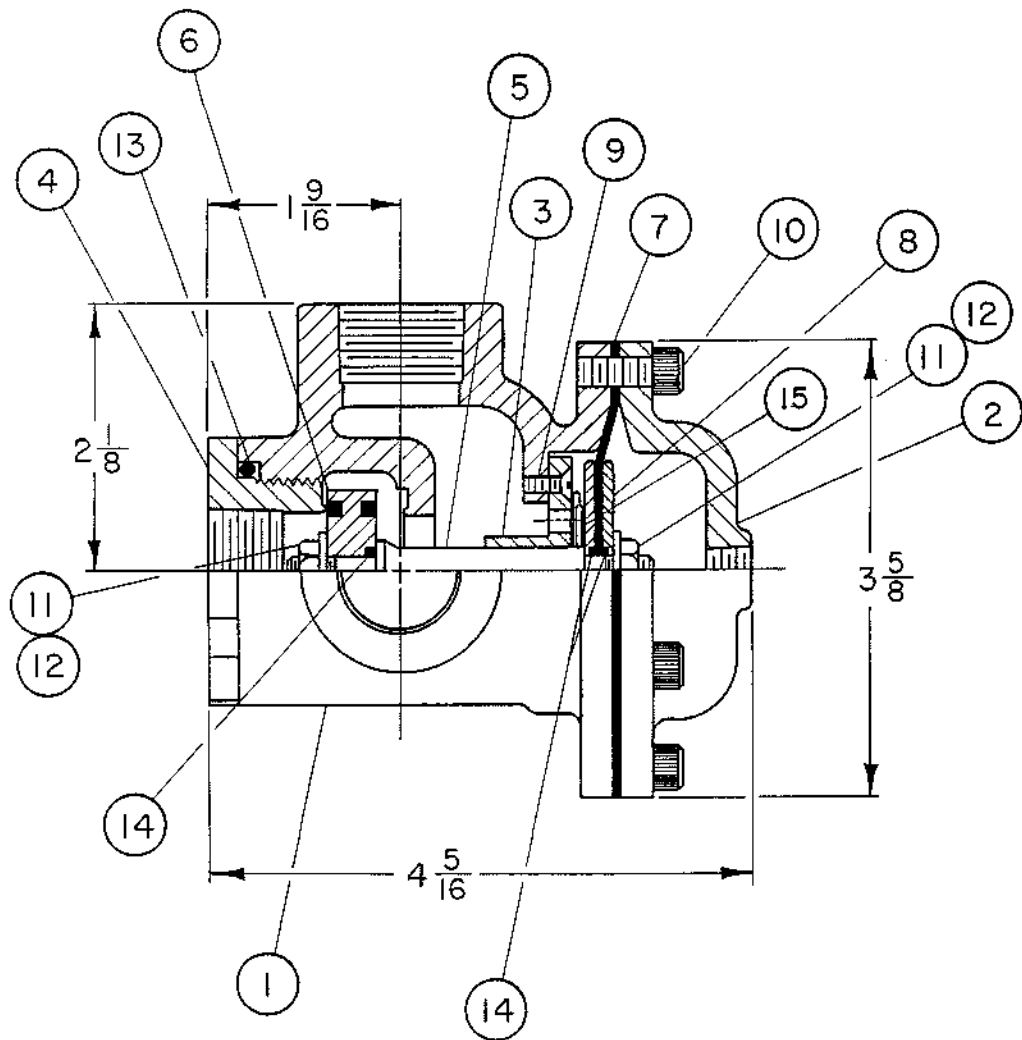

**NOTE:**

1. WHEN ORDERING PARTS, PLEASE SPECIFY; ITEM NO., PART NO. AND MATERIAL.

2. ▲ RECOMMENDED SPARE PARTS.

ITEM	PART NO.	QTY.	DESCRIPTION	MATERIAL
▲ 15	651717	1	SPRING	STAINLESS STEEL
▲ 14	611010	3	O-RING	VITON
▲ 13	610222	1	O-RING	BUNA-N
12	685700	2	LOCKWASHER	STAINLESS STEEL
11	590712	2	HEX HEAD JAM NUT	STAINLESS STEEL
10	530701	6	SOCKET HD. CAPSCREW	STAINLESS STEEL
9	532735	2	FLAT HEAD SCREW	STAINLESS STEEL
8	308135	2	DIAPHRAGM PLATE	BRASS
8	308735	2	DIAPHRAGM PLATE	STAINLESS STEEL
▲ 7	694035	1	DIAPHRAGM	BUNA-N
▲ 7	694135	1	DIAPHRAGM	VITON
▲ 6	310736	1	SEAT DISC	STN. STL./BUNA-N
▲ 6	310737	1	SEAT DISC	STN. STL./VITON
5	314735	1	STEM	STAINLESS STEEL
4	300171	1	ADAPTER	BRASS
4	300771	1	ADAPTER	STAINLESS STEEL
3	300164	1	GUIDE PLATE	BRASS
3	300764	1	GUIDE PLATE	STAINLESS STEEL
2	304135	1	BONNET	BRONZE
2	304735	1	BONNET	STAINLESS STEEL
1	302135	1	BODY	BRONZE
1	302735	1	BODY	STAINLESS STEEL

**PARTS LIST**

E	D	C	B	A
CHG	E. C. NO.	DATE	BY	
REVISIONS				REF DWG NO'S

MATERIAL	TOLERANCES
	UNLESS NOTED FRACTIONAL ± 1/64 DECIMAL ± .005 MACH. FINISH 125/ ANGULAR ± 1/2°
NO REQ'D	DRAWN BY DATE B.R.W. 7-28-83
SCALE	CHKD. BY DATE

**OCV Control Valves**  
TULSA, OKLAHOMA, U.S.A.

**THREE-WAY PILOT**

<b>B</b>	<b>3600S</b>	REV <b>A</b>
----------	--------------	-----------------

## FEATURES

- Chromium plated ball
- Reinforced TFE seats and stuffing box ring
- Blow-out proof stem design
- Adjustable packing gland

## MATERIAL LIST

- |                   |                           |
|-------------------|---------------------------|
| 1. Lever and Grip | Zinc Plated Steel w/Vinyl |
| 2. Stem Packing   | Reinforced TFE            |
| 3. Stem Bearing   | Reinforced TFE            |
| 4. Ball           | Chromium Plated Brass     |
| 5. Seat (2)       | Reinforced TFE            |
| 6. Retainer       | Brass or Bronze - Cast    |
| 7. Gland Nut      | Brass                     |
| 8. Stem           | Brass                     |
| 9. Lever Nut      | Zinc Plated Steel         |
| 10. Seal (1¼"3")  | TFE                       |
| 11. Body          | Bronze - Cast             |

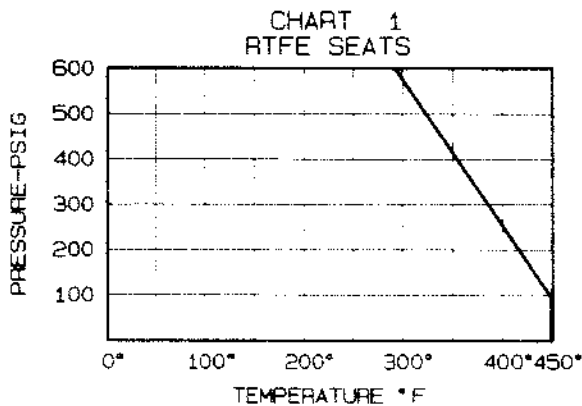

## Bronze Ball Valve; 70-100 Series

Threaded, 600 WOG, Cold, Non-Shock  
150 PSI Saturated Steam,  
Vacuum Service to 29 Inches Hg

### FEDERAL SPECIFICATIONS:

WW-V-35C      Type: II      Composition: BZ  
Style: 3

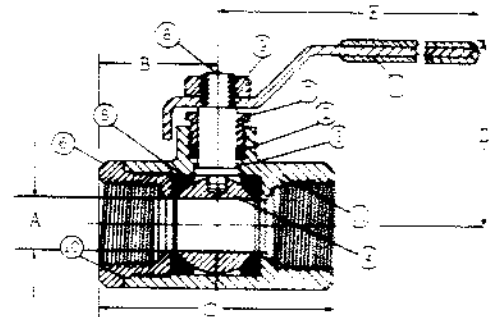

BRONZE THREADED ENDS

NUMBER	SIZE	A	B	C	D	E	Cv*	WT./100
70-101	¼	.37	1.03	2.06	2.75	3.37	6.8	50
70-102	¾	.37	1.03	2.06	2.75	3.37	6.8	56
70-103	½	.50	1.12	2.25	2.75	3.37	9.8	53
70-104	¾	.68	1.50	3.00	2.12	4.37	26	139
70-105	1	.87	1.68	3.37	2.25	4.37	36	172
70-106	1¼	1.00	2.00	4.00	2.62	5.50	47	326
70-107	1½	1.25	2.18	4.37	3.06	6.00	51	461
70-108	2	1.50	2.34	4.68	3.37	6.00	126	606
70-109	2½	2.50	3.25	6.50	4.12	6.00	140	1725
70-100	3	2.50	3.37	6.75	4.12	6.00	350	860

\*The Cv factor is the gallons of water per minute that the valve will pass with 1 P.S.I. pressure drop.

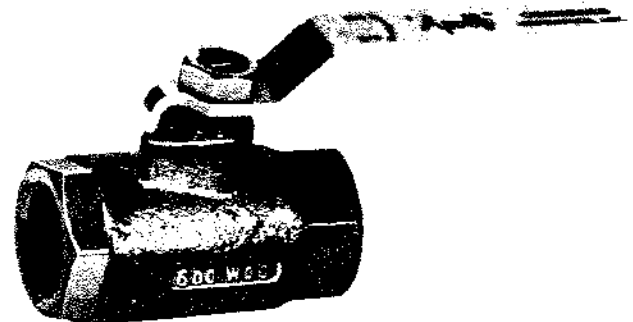

**DESCRIPTION**

The Model 141-4 Ball Valve is a 1/4-turn shutoff device used for isolating the pilot system from the main valve. They are extremely useful for performing routine maintenance and troubleshooting.

Ball valves are standard on water service valves; optional on fuel service valves.

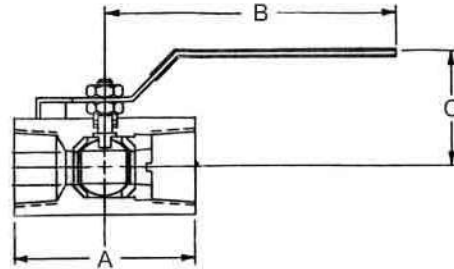

**MODEL 141-4 MATRIX**

MATERIAL	PART NUMBER	INLET/OUTLET (NPT)	A	B	C	USED ON VALVE SIZE*
Bronze	680100	3/8	1 3/4	3 1/2	1 7/8	1 1/4"-6"
Bronze	680101	1/2	2	3 1/2	2 1/4	8"-10"
Bronze	680102	3/4	3	4 3/4	2 1/4	12"-16"
Stn. Steel	680700	3/8	2	3 3/4	2 1/8	1 1/4"-6"
Stn. Steel	680701	1/2	2 1/4	3 3/4	2 1/2	8"-10"
Stn. Steel	680702	3/4	3	4 3/4	2 1/4	12"-16"

**SCHEMATIC SYMBOL**

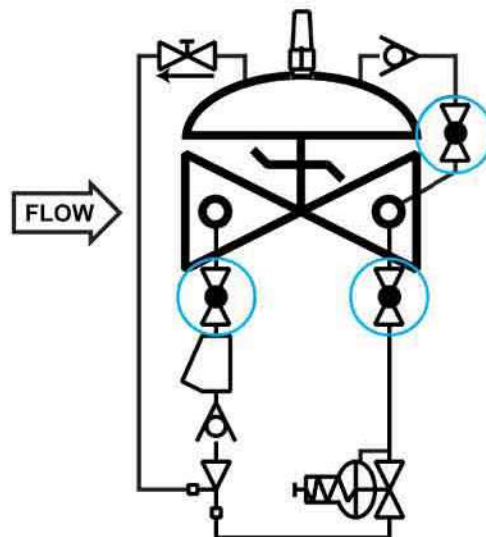

The Model 141-4 Ball Valve is shown on OCV Valve Schematics as:

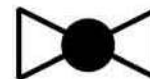

EXAMPLE: Shown here on a MODEL 127-4 Pressure Reducing / Check Valve.





**DESCRIPTION**

**MODEL 159 Y-STRAINER**  
 The 159 Y-Strainer installs in the inlet piping of the pilot system and protects the pilot system from solid contaminants in the line fluid. It is the standard strainer for water service valves.

**MODEL 159 Y-STRAINER MATRIX**

MATERIAL	PART NUMBER	INLET/OUTLET (NPT)	BLOW OFF PORT (NP)	A	STD. MESH	USED ON VALVE SIZE
Bronze	660100	3/8	3/8	2 11/16	24	1 1/4"-6"
Bronze	660101	1/2	3/8	2 5/8	24	8"-10"
Bronze	660102	3/4	3/8	3 5/16	24	12"-16"
Stn. Steel	660700	3/8	1/4	2 1/2	20	1 1/4"-6"
Stn. Steel	660701	1/2	1/4	2 1/2	20	8"-10"
Stn. Steel	660702	3/4	1/4	3 1/8	20	12"-16"

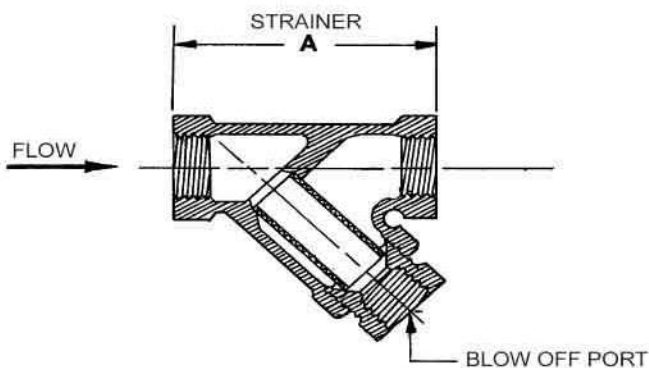

**MATERIALS**

Bronze, ASTM B62  
 Optional mesh sizes: 50, 100  
 Stainless Steel, CF8-M (316)  
 Optional mesh sizes: 60, 80, 100  
 Screens are stainless steel

**SCHEMATIC SYMBOL**

The Model 159 Y-Strainer is shown on OCV Valve Schematics as:

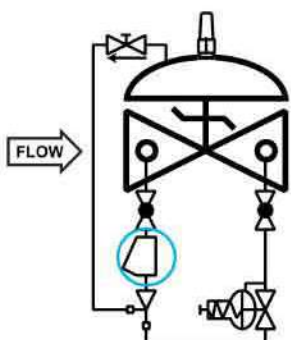

EXAMPLE: Shown here on a MODEL 127-3 Pressure Reducing Valve

**MAINTENANCE**

Routine cleaning and checking of the Y-Strainer will aid in keeping the control valve functioning properly. Pilot system isolation ball valves are supplied on valves equipped with the Model 159 Y-Strainer. These allow flushing of the screen through the blow off port, or removal of the screen itself for manual cleaning.

**DESCRIPTION**

The Model 155 Visual Indicator is a device that enables the user to determine the extent of opening of a control valve. It consists of an adaptor threaded into the center port of the valve bonnet, a rod threaded into the main valve stem, a sealing O-ring, and a protective clear plastic housing. The indicator rod moves as the valve opens and closes. It may be installed on virtually any OCV control valve, and can be done so without any disassembly of the valve itself.

**WHERE USED** - Standard on Series 94 Check Valves, Series 3330 Altitude Valves, and Series 22 Digital Control Valves. Optional on any other valve not employing a limit switch or position transmitter.



**MODEL 155 MATRIX**

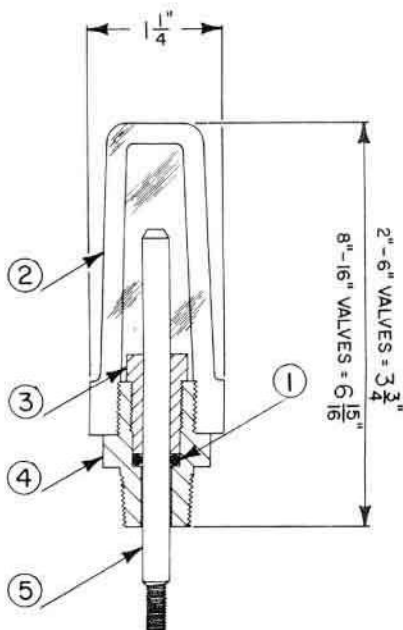

MATERIAL	PART NO. (BRASS ADAPTOR)	PART NO. (STAINLESS ADAPTOR)	VALVE TRAVEL (FULL STROKE)
1 1/4" - 1 1/2"	255100	255700	3/8"
2"	255100	255700	1/2"
2 1/2"	255100	255700	3/4"
3"	255100	255700	1"
4"	255101	255701	1 3/8"
6"	255102	255702	1 1/2"
8" - 10"	255103	255703	2 1/2"
12"	255104	255704	3"
14" - 16"	255105	255705	3 1/2", 4"
24"	255109	255709	6"

ITEM	DESCRIPTION
1	O-Ring
2	Housing
3	Bushing
4	Adaptor
5	Stem

**SCHEMATIC SYMBOL**

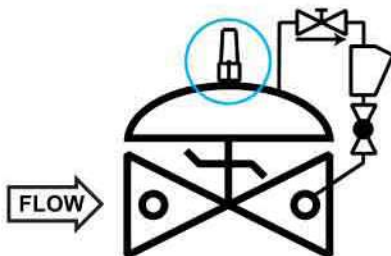

The Model 155 is shown on OCV Valve Schematic as:



EXAMPLE: Shown here on a Model 94-1 Check Valve

**MATERIALS**

- Indicator Rod: Monel
- Adapter: Brass (std.), Stainless Steel (optional)
- Housing: Butyrate (1 1/4" - 6") Acrylic (8" and larger)
- O-Ring: Viton® (std.) Buna-N, EPDM (optional)

**Valve Position Indicator 155**



**Global** performance. **Personal** touch.