

# Operating Manual

**Model: 108FPS**

**Size: "**

**Serial #:**

**Sales Order:**

7400 East 42nd  
Place Tulsa,  
Oklahoma  
74145-4744 USA

**phone:** 918-627-1942  
888-628-8258

**fax:** 918-622-8916

**email:** [sales@controlvalves.com](mailto:sales@controlvalves.com)

**website:** [www.controlvalves.com](http://www.controlvalves.com)



# fire pump suction pressure sustaining valve

## installation, operating and maintenance instructions

# model 108FPS

Ron 2-25-03

### GENERAL DESCRIPTION

The OCV Model 108FPS is described as a **fire pump suction control valve**, i.e., it controls the suction pressure of a fire pump preventing it from falling below a predetermined minimum. The 108FPS is **Factory Mutual Approved** in sizes 3" through 8", globe and angle patterns, with an adjustment range of 5-30 psi. It consists of the following components, arranged as shown on the schematic diagram:

1. **Model 65 Basic Control Valve**, a hydraulically-operated, diaphragm-actuated, globe or angle valve which closes with an elastomer-on-metal seal.
2. **Model 1330HB Pressure Sustaining Pilot**, a two-way, normally-closed pilot valve which senses pump suction pressure under its diaphragm and balances it against an adjustable spring load. An increase in pump suction pressure tends to make the pilot open.
3. **Model 126 Ejector**, a simple "tee" fitting with a fixed orifice in its inlet port. It provides the proper pressure to the diaphragm chamber of the main valve depending on the position of the pressure relief pilot.
4. **Model 141-3 Flow Control Valve**, a needle-type valve which provides adjustable, restricted flow in one direction, and free flow in the opposite direction. On the 108FPS, the flow control valve is connected as an **opening speed control**.

5. **Model 159 Y-Strainer**. The strainer protects the pilot system from solid contaminants in the line fluid.
6. **Model 155 Visual Indicator**. The visual indicator allows the user to see the valve's position at a glance.

### THEORY OF OPERATION

To understand how the 108FPS operates, it is best to start with the **Ejector (3)**. Due to the orifice in its upstream port, the ejector creates a pressure drop proportional to the flow through it. The flow through the ejector is in turn controlled by the degree of opening of the **Pressure Sustaining Pilot (2)**. The **wider** the pilot opens, the **greater the flow** through the ejector and the **lower the pressure** downstream of the orifice. Conversely, the **more** the pilot closes, the **lower the flow** through the ejector and the **greater the pressure** downstream of the orifice.

Now note that the diaphragm chamber of the Main Valve (1) is connected to the branch port of the ejector and is thus downstream of the orifice. Therefore, the pressure in the diaphragm chamber of the main valve is effectively controlled by the pressure sustaining pilot, in the manner described above. As the pilot **opens**, the diaphragm pressure **decreases** and the main valve **opens**; as the pilot **closes**, the diaphragm pressure **increases** and the main valve **closes**.

### INSTALLATION

The 108FPS is furnished fully factory-assembled

and ready for installation at the appropriate point in the system.

For full installation details, the user is referred to the Model 65 Basic Valve section of this manual.

### START-UP AND ADJUSTMENTS

The following procedures should be followed in the order presented in order to affect an initial startup of the 108FPS.

1. Install a pressure gauge of the proper range on the pump suction side of the system.
2. Remove the plastic cap from the pressure sustaining pilot (2) and loosen the adjusting screw jam nut. Turn the adjusting screw **clockwise** to a full stop.
3. Loosen the adjusting screw jam nut on the flow control valve (4) (opening speed control). Turn the adjusting screw **clockwise** to a full stop, then **counterclockwise** three full turns.
4. Start the pump. The main valve at this time should be fully closed.
5. Carefully loosen a pipe plug in the main valve bonnet until fluid begins to discharge around the threads. When only clear fluid (no air) is discharging, retighten the plug.
6. Turn the adjusting screw of the pressure sustaining pilot (2) counterclockwise until it is loose enough to be turned with the fingers. The main valve should open fully.
7. Observing the pump suction pressure gauge, open valves or otherwise increase flow until the pump suction pressure falls to a point approximately 5 psi below the desired set point.
8. Slowly turn the adjusting screw of the pressure sustaining pilot (2) clockwise until the pump suction pressure rises to the set point. Tighten the adjusting screw jam nut and replace the plastic cap.
9. Shut down the pump.

### MAINTENANCE

Because of the simplicity of design of the 108FPS, required maintenance is minimal. However, the following checks, periodically performed, can do much to keep the valve operating properly and efficiently.

1. Check for chipped or peeling paint. Touch up as required.
2. Check for leaks at fittings and around flanges and connections. Tighten as required.
3. If the valve is equipped with a Y-strainer, check the screen for buildup of solid material. Clean as required. This point is most important, as a clogged strainer can keep the valve from closing. On new installations, it is recommended that the strainer be checked every day or two until experience dictates a greater or lesser interval. Strainer maintenance is covered in detail on a special page later in this manual.

### TROUBLESHOOTING

In the event of malfunction of the 108FPS, the following guide should enable the technician to isolate the specific cause of the problem and take the appropriate corrective action.

#### A. MAIN VALVE FAILS TO OPEN:

1. Valve closed upstream or downstream of the 108FPS. Open as required.
2. Opening speed control (4) adjusted fully closed. Open as required. See Adjustment instructions.
3. Pressure sustaining pilot (2) adjusted too far clockwise. See Adjustment instructions.
4. Diaphragm of pressure sustaining pilot (2) ruptured. This will be evidenced by a discharge of fluid from the vent hole in the pilot bonnet. Replace diaphragm. See the 1330HB Pilot section of this manual.
5. Stem of pressure sustaining pilot (2) binding. Disassemble pilot and determine cause. See the 1330HB Pilot section of this manual.

6. Stem of main valve binding. Disassemble valve and determine cause. See the Model 65 Basic Valve section of this manual.

**B. MAIN VALVE FAILS TO CLOSE:**

1. Strainer (5) clogged. Clean as required.
2. Pressure sustaining pilot (2) adjusted too far counterclockwise. See Adjustment instructions.
3. Pressure sustaining pilot (2) stem binding or seat badly deteriorated. Disassemble pilot and determine cause. See the 1330HB Pilot section of this manual.
4. Main valve stem binding or object caught in valve. Disassemble valve and determine cause. See the Model 65 Basic Valve section of this manual.

# MODEL 108FPS

RON  
2-25-03

## FIRE PUMP SUCTION CONTROL VALVE

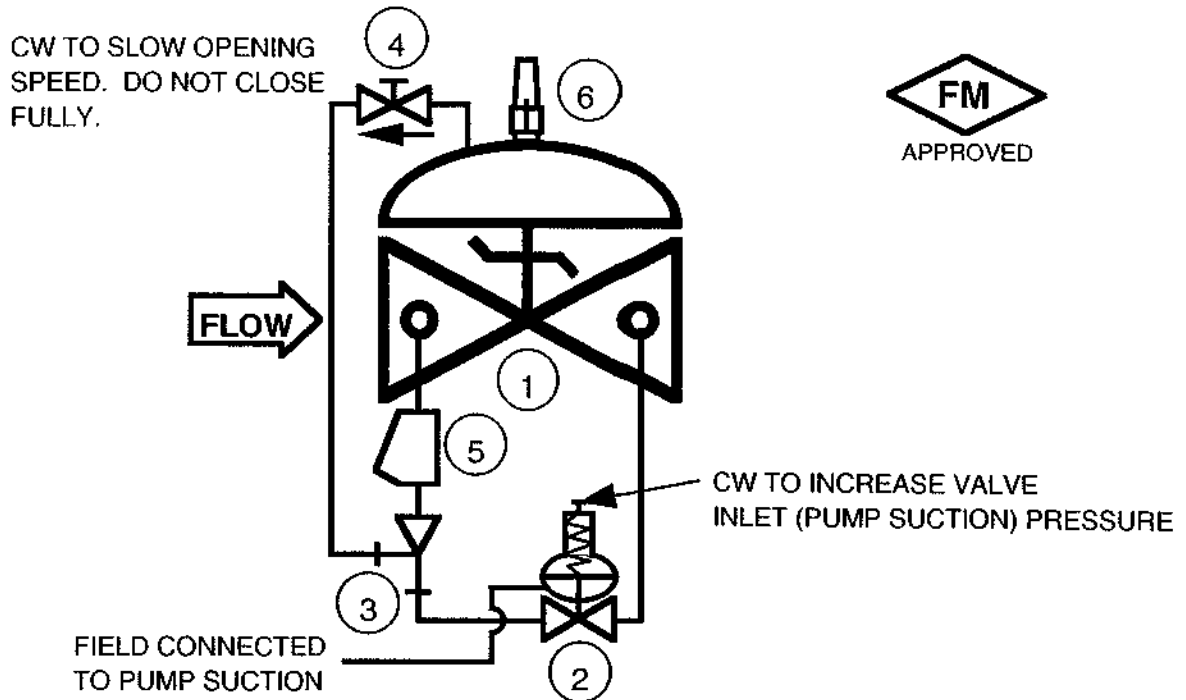

### OPERATION:

THE VALVE IS INSTALLED ON THE **DISCHARGE** OF A FIRE PUMP. THE SENSE LINE FROM PILOT(2) IS CONNECTED TO THE **SUCTION** SIDE OF THE PUMP. AS LONG AS PUMP SUCTION PRESSURE IS ABOVE THE SET POINT OF THE PILOT, THE VALVE WILL OPEN FULLY AND ALLOW FULL PUMP FLOW. HOWEVER, IF PUMP SUCTION PRESSURE TENDS TO FALL BELOW THE SET POINT, THE VALVE WILL BEGIN TO CLOSE AND THROTTLE FLOW TO PREVENT PUMP SUCTION PRESSURE FROM FALLING ANY FURTHER.

### ADJUSTMENT:

**CLOCKWISE** ADJUSTMENT OF THE PILOT **INCREASES** SUCTION PRESSURE.

### ADJUSTMENT RANGE:

**5 - 30 PSI**

ITEM	PART NO.	QTY	DESCRIPTION
1	65	1	BASIC VALVE ASSEMBLY
2	1330HB	1	PRESSURE SUSTAINING PILOT
3	126	1	EJECTOR
4	141-3	1	FLOW CONTROL VALVE (Opening Speed Control)
5	159	1	Y-STRAINER
6	155	1	VISUAL INDICATOR



7400 East 42nd Place • Tulsa, Oklahoma 74145-4744 U.S.A.  
 Phone: 888-628-8258 • 918-627-1942 • Fax: 918-622-8916 • e-mail: ocv@controlvalves.com  
 • website: www.controlvalves.com

# installation, operating, and maintenance instructions

## series 65

### basic control valve

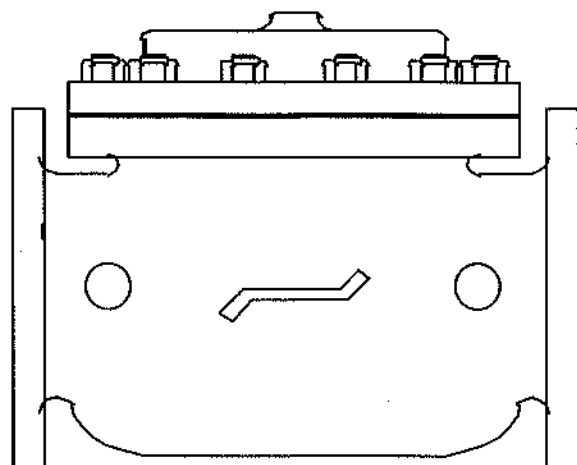

#### GENERAL DESCRIPTION

The OCV Series 65 is a hydraulically-operated, diaphragm-actuated valve. It is available in either a globe (Model 65) or angle (Model 65A) configuration. The diaphragm is nylon-fabric bonded with synthetic rubber and forms a sealed chamber in the upper portion of the valve, separating operating pressure from line pressure. An elastomeric seat forms a tight seal with the valve seat when pressure is applied above the diaphragm.

#### FUNCTIONAL DESCRIPTION

Because the Series 65 is a hydraulically operated valve, it requires a minimum line pressure of approximately 5 psig in order to function. The valve functions on a simple principle of pressure differential. The line pressure at the inlet of the valve is bypassed through the pilot control piping to the diaphragm chamber of the valve. This pressure, together with the valve spring, works against the pressure under the valve seat. Because the effective area of the diaphragm is greater than that of the seat, the valve is held tightly closed. As the controlling pilot(s) allow the pressure to bleed off the diaphragm chamber, the two opposing pressures begin to balance and the valve will begin to open. The valve can be used to perform a simple on-off function, or with the proper pilot system, a modulating, or regulating function.

In cases where the line fluid is unusually dirty, or is otherwise unsuitable for operating the valve, an independent operating pressure source may be employed. The pressure available from such a source must be equal to, or greater than, line pressure.

#### INSTALLATION

In order to insure safe, accurate and efficient operation of the OCV control valve, the following list of checkpoints and procedures should be followed when installing the valve.

1. Make a careful visual inspection of the valve to insure that there has been no damage to the external piping, fittings or controls. Check that all fittings are tight.
2. Thoroughly flush all interconnecting piping of chips, scale and foreign matter prior to mounting the valve.
3. Install the valve in the line according to the flow arrow on the inlet flange. The arrow should point downstream.
4. Allow sufficient room around the valve for ease of adjustment and maintenance service.

In addition, it is highly recommended that:

1. Isolation valves (eg., gate or butterfly) be installed on the inlet and discharge sides of the valve to facilitate isolating the valve for maintenance.
2. Pressure gauges be installed at the inlet and outlet sides of the valve to provide monitoring of the valve during initial start-up and during operation. The body side ports, if unused by the pilot system, provide a convenient connection for the gauges.
3. All valves larger than 6" be installed horizontally, i.e., with the bonnet pointed up, for ease of adjustment and maintenance servicing.

## MAINTENANCE

The OCV control valve requires no lubrication and a minimum of maintenance. However, a periodic inspection should be established to determine how the fluid being handled is affecting the efficiency of the valve. In a water system, for example, the fluid velocity as well as the substances occurring in natural waters, such as dissolved minerals and suspended particles, vary in every installation. The effect of these actions or substances must be determined by inspection. It is recommended that an annual inspection, which includes examination of the valve interior, be conducted. Particular attention should be paid to the elastomeric parts, i.e., the diaphragm and seat disc. Any obviously worn parts should be replaced.

## REPAIR PROCEDURES

In the event of malfunction of the OCV control valve, troubleshooting should be conducted according to the procedures outlined for the specific model of valve. Then, if those steps indicate a problem with the main valve, this section will outline the procedures necessary to correct the problem.

Problems with the main valve can be classed in three basic categories:

1. VALVE FAILS TO OPEN
  - a. Diaphragm damaged\* - See Procedure A

- b. Stem binding - See Procedure B

2. VALVE FAILS TO CLOSE

- a. Diaphragm damaged\* - See Procedure A
- b. Stem binding - See Procedure B
- c. Object lodged in valve - See Procedure B

3. VALVE OPENS AND CLOSES BUT LEAKS WHEN CLOSED

- a. Seat disc damaged - See Procedure C
- b. Seat ring damaged - See Procedure D

\*A diaphragm failure can prevent the valve from either opening or closing, depending on the flow direction. Most water service valves flow "under the seat", in which case a diaphragm failure will keep the valve from closing. On the other hand, most fuel service valves flow "over the seat", in which case a diaphragm failure will keep the valve from opening. To determine which you have, examine the bridge mark cast into the side of the valve body, then compare it with the figures below.

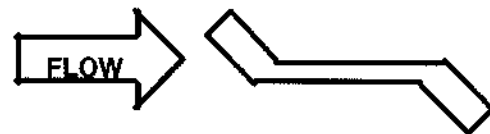

FLOW UNDER SEAT  
DIAPHRAGM FAILURE = VALVE FAILS TO CLOSE

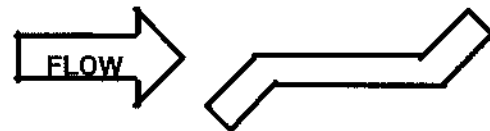

FLOW OVER SEAT  
DIAPHRAGM FAILURE = VALVE FAILS TO OPEN

### PROCEDURE A : DIAPHRAGM REPLACEMENT

1. Isolate the valve from the system by closing upstream and downstream block valves.

2. Loosen one of the tubing connections on the bonnet. Allow any residual pressure to bleed off.
3. Remove all tubing connected at the bonnet.
4. Remove the bonnet nuts.
5. Remove the bonnet. If the bonnet sticks in place, it may be loosened by rapping sharply around its edge with a *rubber-headed* mallet. *NOTE: 8" and larger valves are equipped with eye bolts through which a chain can be fastened to aid in lifting the bonnet.*
6. Remove the spring.
7. Remove the diaphragm plate capscrews and the diaphragm plate.
8. Remove the old diaphragm.
9. Making sure the dowel pin holes are in the proper location, place the new diaphragm over the studs and press down until it is flat against the body and spool.
10. Replace the diaphragm plate and the diaphragm plate capscrews.
11. Tighten all diaphragm plate capscrews snugly.
12. Replace the spring.
13. Replace the bonnet and reinstall the bonnet nuts.
14. Tighten the bonnet nuts snugly using a criss-cross tightening pattern.
15. Reinstall the control tubing.
16. Reopen the upstream and downstream block valves.
17. Before placing the valve back in service, perform the air bleed procedure described in the first section of this manual.

PROCEDURE B: CORRECTION OF BINDING STEM

1. Perform Steps 1 thru 6 of Procedure A, above.
2. Remove the spool assembly from the valve. *NOTE: On smaller valves, this can be accomplished simply by grasping the stem and pulling upward. Valves 6" and larger have the top of the stem threaded to accept an eyebolt to aid in lifting the spool out of the body. 6" thru 12" valves are threaded 3/8-16. 14" and 16" valves are threaded 5/8-11.*
3. Carefully examine both ends of the stem for deep scratches, scoring or buildup of mineral deposits. Polish the stem if necessary using a fine grade of emery cloth.
4. Similarly, examine and polish the upper bushing (in the bonnet) and the lower guide (in the seat ring).
5. Reinstall the spool assembly.
6. Reassemble the valve, following Steps 12 thru 17 in Procedure A.

PROCEDURE C: SEAT DISC REPLACEMENT

1. Perform Steps 1 and 2 of Procedure B, above.
2. With the spool assembly removed from the body, remove the seat retainer screws.
3. Slide the seat retainer off the lower end of the stem.
4. Remove the seat disc from its groove in the spool. *NOTE: The seat disc may fit quite tightly in the groove. If necessary, it may be pried out using a thin-bladed screwdriver or similar tool.*
5. Install the new seat disc in the groove.
6. Reinstall the seat retainer and tighten the seat retainer screws.
7. Reassemble the valve, following Steps 5 and 6 of Procedure B.



PROCEDURE D: SEAT RING REPLACEMENT

*NOTE: It is rare for a seat ring to require replacement. Minor nicks and scratches in the seating surface can usually be smoothed out with emery cloth.*

1. Perform Steps 1 and 2 of Procedure B, above.
2. If you are working on a 4" or smaller valve, follow Steps 3 thru 9, below.
3. If you are working on a 6" or larger valve, follow Steps 10 thru 16, below.
4. Seat rings in valves 4" and smaller are threaded into the valve body. To remove, you will need a special seat ring tool. You may fabricate one using standard pipe as shown in the sketch below, or one may be purchased from OCV.
5. Using the seat ring tool, unthread the seat ring from the body.
6. Remove the old o-ring from the counterbore in the body.
7. Install the new o-ring in the counterbore.
8. Using the seat ring tool, install the new seat ring.
9. Reassemble the valve, following Steps 5 & 6 of Procedure B.
10. Seat rings in valves 6" and larger are bolted into the body with socket head capscrews. In addition you will note that the seat ring is equipped with additional threaded holes that may be used for "jacking" the seat ring out of the body.
11. Remove the socket head capscrews.
12. Remove the old seat ring from the body by temporarily installing two or more of the capscrews in the "jacking" holes.
13. Install a new o-ring in the groove of the new seat ring. Lubricate the o-ring and outer seat ring wall with Vaseline® or similar lubricant.
14. Install the new seat ring in the body, making sure that the capscrew holes line up.
15. Replace and tighten all the capscrews.
16. Reassemble the valve, following Steps 5 and 6 of Procedure B.

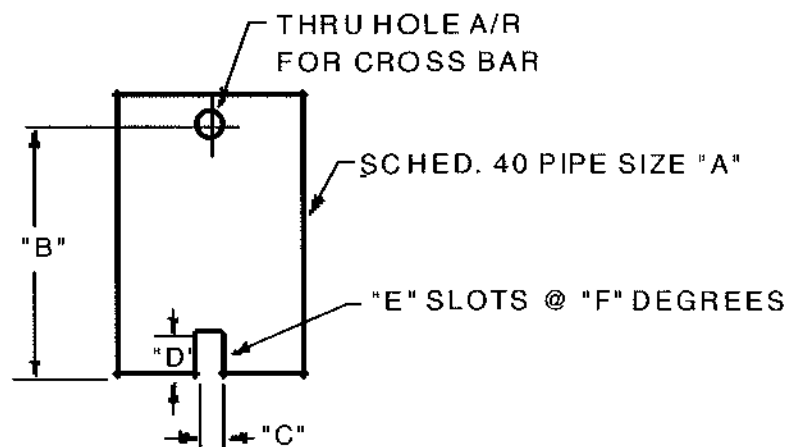

VALVE SIZE	"A" PIPE SIZE	"B" MIN. LENGTH	"C" SLOT WIDTH	"D" SLOT DEPTH	"E" NO. OF SLOTS	"F" SLOT SPACING
1-1/4"	3/4"	6"	3/8"	3/8"	2	180°
1-1/2"	3/4"	6"	3/8"	3/8"	2	180°
2"	1-1/2"	7"	3/8"	3/8"	2	180°
2-1/2"	2"	8"	1/2"	1/2"	3	120°
3"	2-1/2"	9"	5/8"	5/8"	2	180°
4"	3"	10"	5/8"	5/8"	2	180°

REVISED 3-17-97

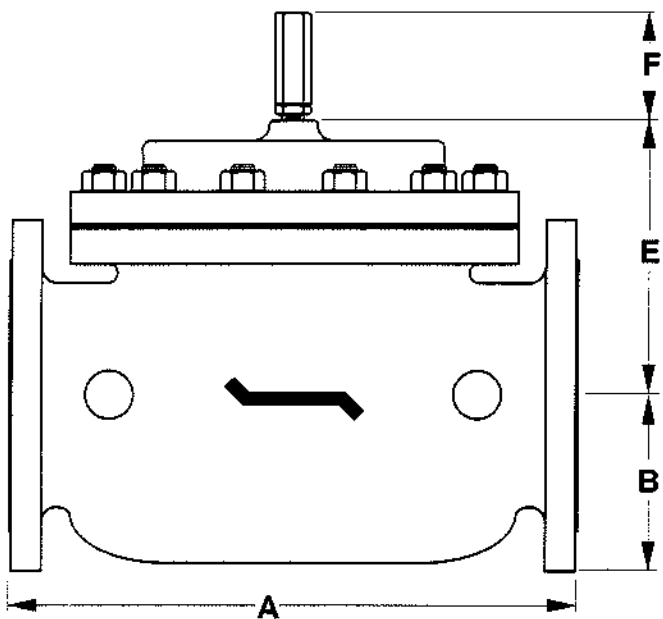
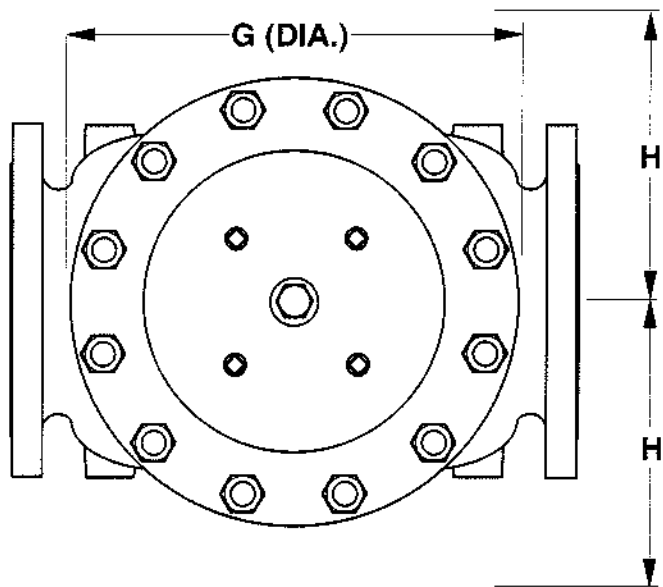

DIM	ANSI CLASS	VALVE SIZE												
		1 1/4	1 1/2	2	2 1/2	3	4	6	8	10	12	14	16	24
A	SE	8.75	8.75	9.88	10.50	13.00	-	-	-	-	-	-	-	-
	150	8.50	8.50	9.38	10.50	12.00	15.00	17.75	25.38	29.75	34.00	39.00	40.38	62.00
	300	8.75	8.75	9.88	11.12	12.75	15.63	18.62	26.38	31.12	35.50	40.50	42.00	63.75
B	SE	1.44	1.44	1.69	1.88	2.25	-	-	-	-	-	-	-	-
	150	2.31	2.50	3.00	3.50	3.75	4.50	5.50	6.75	8.00	9.50	10.62	11.75	16.00
	300	2.62	3.06	3.25	3.75	4.12	5.00	6.25	7.50	8.75	10.25	11.50	12.75	18.00
C	SE	4.38	4.38	4.75	6.00	6.50	-	-	-	-	-	-	-	-
	150	4.25	4.25	4.75	6.00	6.00	7.50	10.00	12.69	14.88	17.00	-	20.81	-
	300	4.38	4.38	5.00	6.38	6.38	7.81	10.50	13.19	15.56	17.75	-	21.62	-
D	SE	3.12	3.12	3.88	4.00	4.50	-	-	-	-	-	-	-	-
	150	3.00	3.00	3.88	4.00	4.00	5.50	6.00	8.00	11.38	11.00	-	15.69	-
	300	3.25	3.25	4.12	4.38	4.38	5.81	6.50	8.50	12.06	11.75	-	16.50	-
E	ALL	6.00	6.00	6.00	7.00	6.50	8.00	10.00	11.88	15.38	17.00	18.00	19.00	27.00
F	ALL	3.88	3.88	3.88	3.88	3.88	3.88	3.88	6.38	6.38	6.38	6.38	6.38	8.00
G	ALL	6.00	6.00	6.75	7.69	8.75	11.75	14.00	21.00	24.50	28.00	31.25	34.50	52.00
H	ALL	10.00	10.00	11.00	11.00	11.00	12.00	13.00	14.00	17.00	18.00	20.00	20.00	28.50

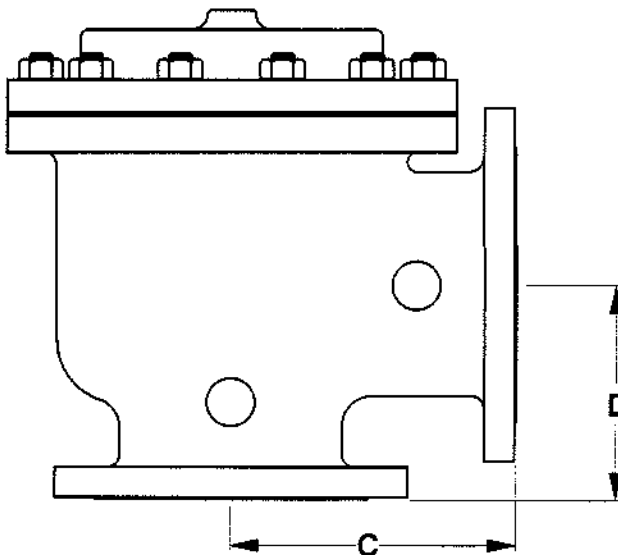
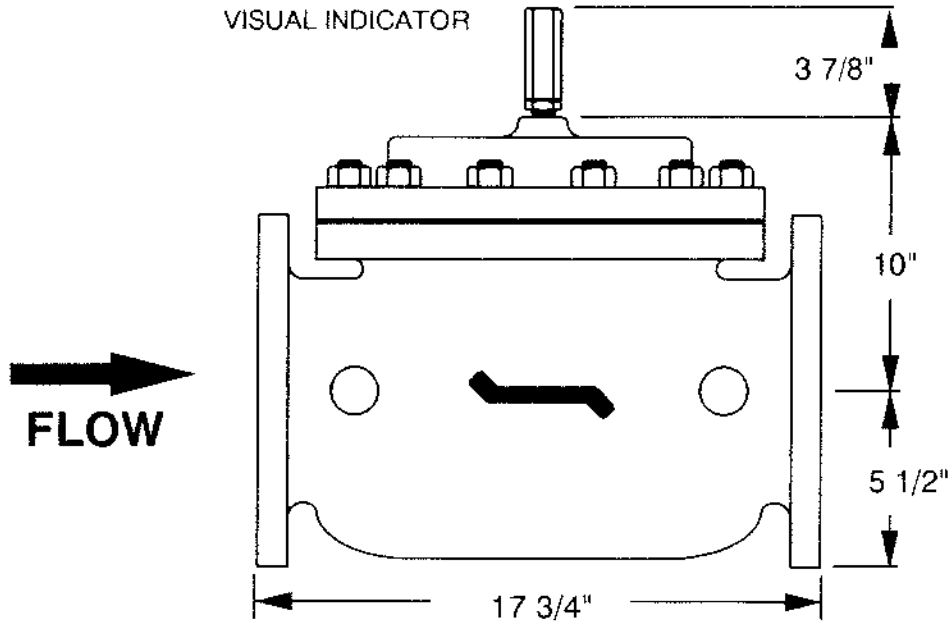
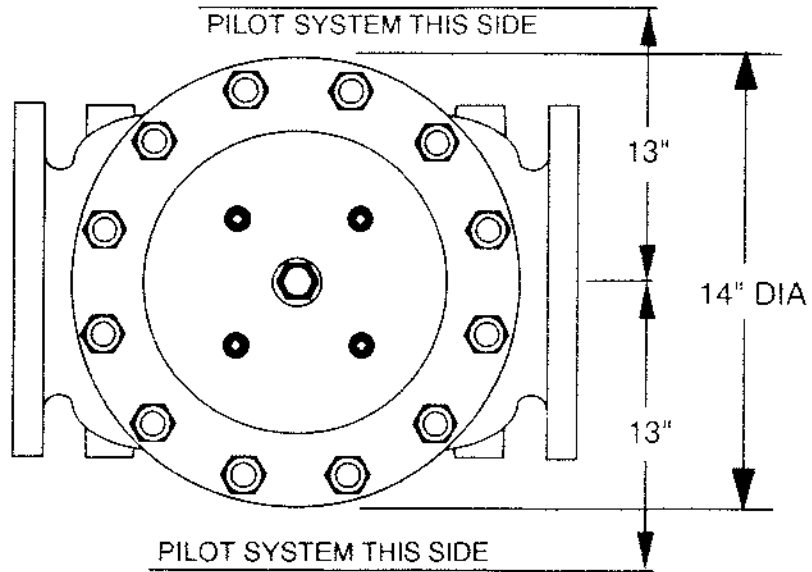

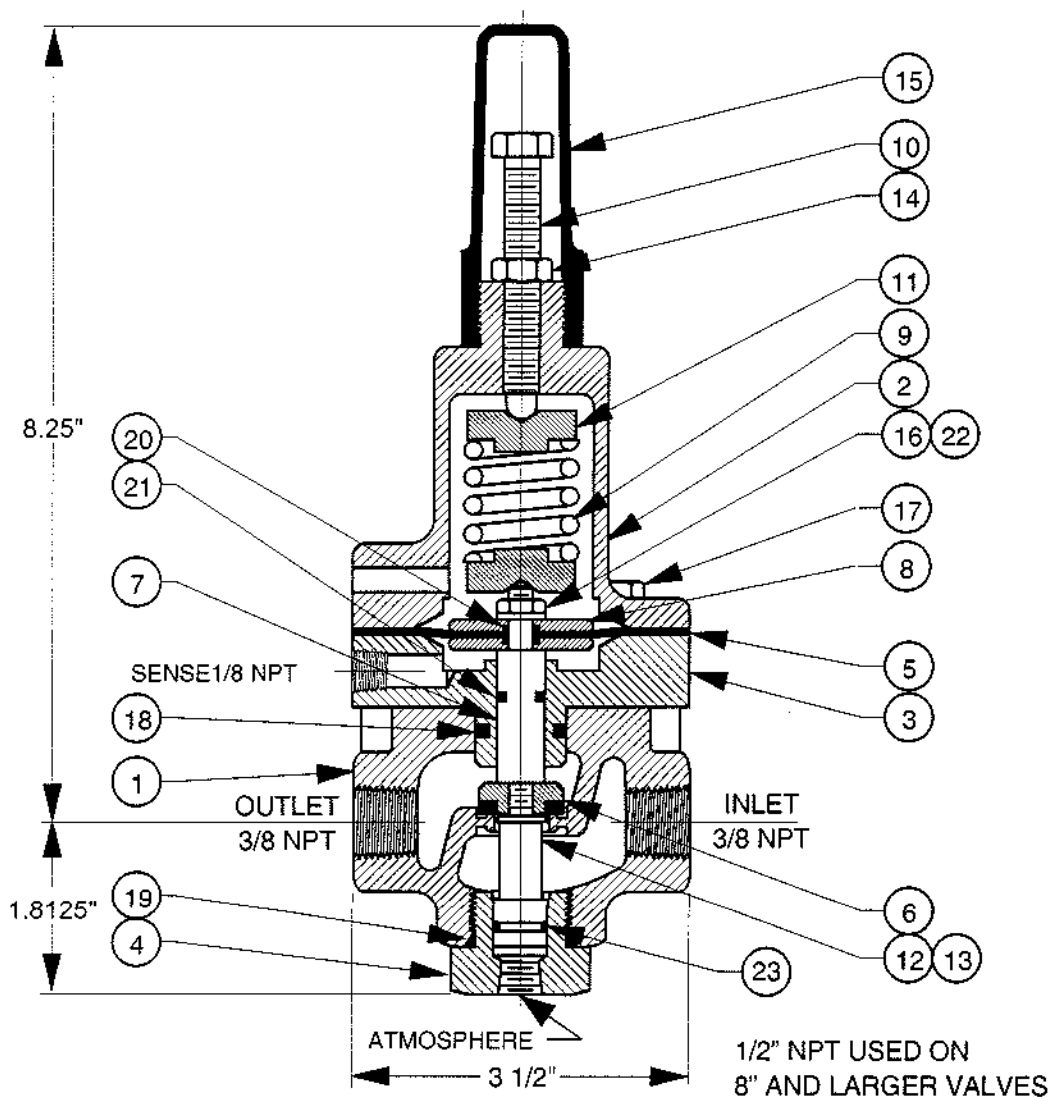

TABLE DEPICTS  
 3" SERIES 3100  
 4" SERIES 4400  
 8" SERIES 3200  
 10" SERIES 3800

TOLERANCES		OCV Control Valves TULSA, OKLAHOMA U.S.A.	
GENERAL ENVELOPE		GENERAL VALVE DIMENSIONS	
DRAWN BY RON	DATE 11-7-02	SIZE <b>A</b>	DRAWING NUMBER <b>65D</b>
CHKD. BY	DATE		REV.



				<b>MATERIAL</b>	<b>TOLERANCES</b>	 <b>OCV Control Valves</b> TULSA, OKLAHOMA U.S.A.			
					FACE TO FACE FRACTIONAL $\pm 3/32"$				
					OTHERS GENERAL ENVELOPE	<b>DIMENSIONAL INSTALLATION</b>			
				NO. REQ'D	DRAWN BY	DATE	<b>6" 150# GLOBE</b>		
CHG	E.C. NO.	DATE	BY	RON	8-5-96	SIZE	DRAWING NUMBER	REV.	
<b>REVISIONS</b>				SCALE	CHKD. BY	DATE	<b>A</b>	<b>6" 65D</b>	
				NONE					



▲ = RECOMMENDED SPARE PARTS  
 (INCLUDED IN REPAIR KIT PN 930000) ADD 611013  
 VITON ELASTOMERS AVAILABLE  
 1/2" NPT AVAILABLE  
 STN STL CONSTRUCTION AVAILABLE

ITEM	PART NO.	QTY	DESCRIPTION	MATERIAL
▲ 23	611013	1	O-RING	VITON
▲ 22	685700	1	LOCKWASHER	STN. STEEL
▲ 21	611012	1	O-RING	VITON
▲ 20	611010	2	O-RING	VITON
▲ 19	610912	1	O-RING	BUNA-N
▲ 18	611116	1	O-RING	VITON
17	531701	4	HEX HD CAPSCREW	STN. STEEL
16	590712	1	HEX NUT	STN. STEEL
15	692002	1	CAP	PVC
14	590717	1	HEX NUT	STN. STEEL
▲ 13	685760	1	LOCKWASHER	STN. STEEL
12	300804	1	C'BALANCE STEM	STN. STEEL
11	300134	2	SPRING RETAINER	BRASS
10	300700	1	ADJUSTING SCREW	STN. STEEL
9	651701	1	SPRING (5-30 PSI)	STN. STEEL
8	308102	2	DIAPHRAGM PLATE	BRASS
7	314702	1	STEM	STN. STEEL
▲ 6	310703	1	SEAT DISC	BUNA-N/SS
▲ 5	694002	1	DIAPHRAGM	BUNA-N/NYLON
4	310725	1	PLUG	STN. STEEL
3	300129	1	ADAPTER	BRONZE
2	304102	1	BONNET	BRONZE
1	302102	1	BODY (302104 1/2")	BRONZE

CHG	E.C. NO.	DATE	BY	REVISIONS	REF DWG NO'S

MATERIAL	TOLERANCES
BRONZE / BUNA-N	GENERAL ENVELOPE
NO. REQ'D	DRAWN BY RON
SCALE 1/2	DATE 3-5-03
	CHKD. BY
	DATE

**Control Valves** TULSA, OKLAHOMA U.S.A.

**PILOT, 1330HB 3/8 NPT BRONZE / BUNA-N  
 PRESSURE SUSTAINING (5-30 PSI ADJ RANGE)**

SIZE	DRAWING NUMBER	REV.
<b>A</b>	<b>1330HB</b>	

**DESCRIPTION**



**MODEL 126 EJECTOR**  
 The Model 126 ejector is a simple tee fitting with a fixed orifice in its inlet port. It provides the proper supply pressure to the main valve diaphragm chamber, allowing various two-way control pilots to control the valve position.

**MODEL 126 EJECTOR DIAGRAM**

Brass Construction / Stainless Steel Construction

MATERIAL	PART NUMBER	P (NPT)	T-TUBE O.D.	STD. ORIFICE	USED ON VALVE SIZES
Brass	213100	3/8"	3/8"	.125"	1 1/4"-6"
Brass	214100	1/2"	1/2"	.188"	8"-10"
Brass	215100	3/4"	3/4"	.188"	12"-16"
316 Stn. Steel	213700	1/4"	3/8"	.090"	1 1/4"-6"
316 Stn. Steel	214700	3/8"	1/2"	.125"	8"-10"
316 Stn. Steel	215700	1/2"	3/4"	.188"	12"-16"

Orifice bushings are stainless steel.

STAINLESS

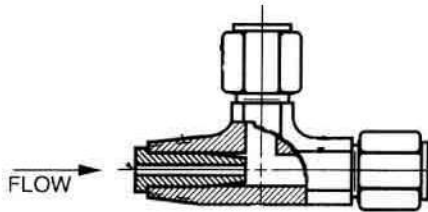

BRASS

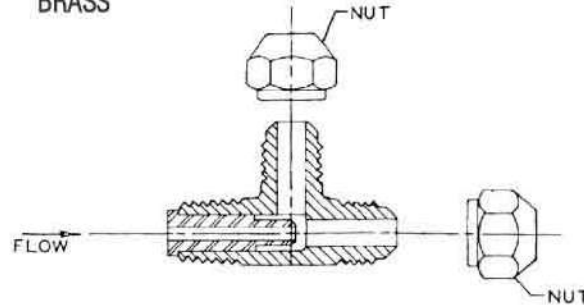

**SCHEMATIC SYMBOL**

The Model 126 Ejector is shown on OCV Valve Schematics as:

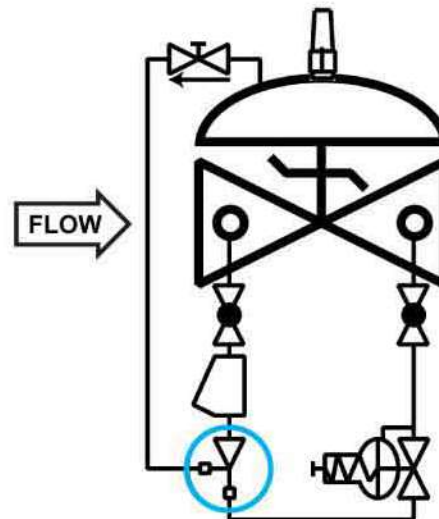
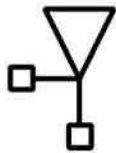

EXAMPLE: Shown here on a MODEL 127-3 Pressure Reducing Valve

**DESCRIPTION**



The Model 141-3 Flow Control Valve is an adjustable restriction device, installed in the control circuit tubing. The flow control valve differs from a standard needle valve in that it includes an internal check valve. Thus it allows free flow in one direction (through the check) and restricted flow in the other direction (through the needle). The setting of the flow control valve meters the flow into or out of the main valve diaphragm chamber,

thus controlling either the opening or closing speed of the main valve. These can be installed in series for separate opening and closing speed control. Restricted flow is in the direction of the flow arrow on the body.

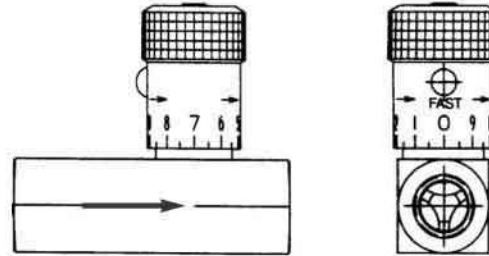

**MODEL 141-3 MATRIX**

MATERIAL	PART NUMBER	INLET/OUTLET (NPT)	A	USED ON VALVE SIZE*
Brass	682100	1/4	2 3/8	1 1/4"-2"
Brass	682101	3/8	2 3/4	2 1/2"-6"
Brass	682102	1/2	3 1/4	8"-10"
Brass	682103	3/4	3 7/8	12"-16"
Stn. Steel	682700	1/4	2 3/8	1 1/4"-2" Stn.
Stn. Steel	682701	3/8	2 3/4	2 1/2"-6"
Stn. Steel	682702	1/2	3 1/4	8"-10"
Stn. Steel	682703	3/4	3 5/8	12"-16"

Note: Flow control valve use and size may vary on valve application. Consult factory.

**SCHEMATIC SYMBOL**

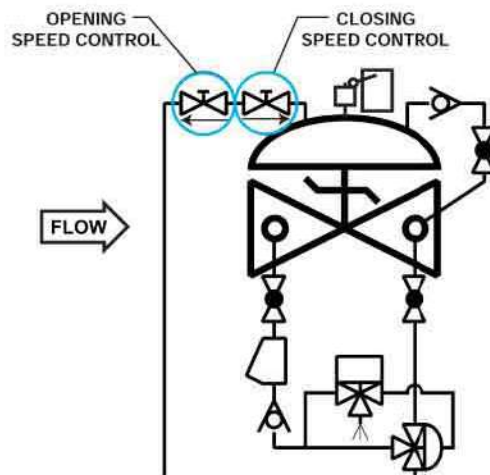

The Model 141-3 Flow Control Valve is shown on OCV Valve Schematics as:

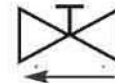

EXAMPLE: Shown here on a MODEL 125 Pump Control Valve as separate opening and closing speeds.

**Flow Control Valves 141-3**





**DESCRIPTION**

**MODEL 159 Y-STRAINER**

The 159 Y-Strainer installs in the inlet piping of the pilot system and protects the pilot system from solid contaminants in the line fluid. It is the standard strainer for water service valves.

**MODEL 159 Y-STRAINER MATRIX**

MATERIAL	PART NUMBER	INLET/OUTLET (NPT)	BLOW OFF PORT (NP)	A	STD. MESH	USED ON VALVE SIZE
Bronze	660100	3/8	3/8	2 11/16	24	1 1/4"-6"
Bronze	660101	1/2	3/8	2 5/8	24	8"-10"
Bronze	660102	3/4	3/8	3 5/16	24	12"-16"
Stn. Steel	660700	3/8	1/4	2 1/2	20	1 1/4"-6"
Stn. Steel	660701	1/2	1/4	2 1/2	20	8"-10"
Stn. Steel	660702	3/4	1/4	3 1/8	20	12"-16"

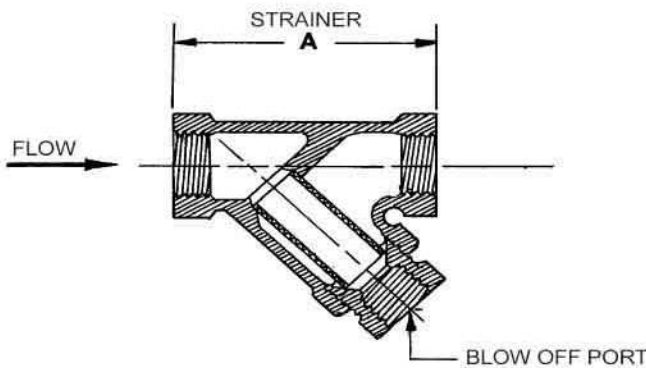

**MATERIALS**

Bronze, ASTM B62  
Optional mesh sizes: 50, 100

Stainless Steel, CF8-M (316)  
Optional mesh sizes: 60, 80, 100

Screens are stainless steel

**SCHEMATIC SYMBOL**

The Model 159 Y-Strainer is shown on OCV Valve Schematics as:

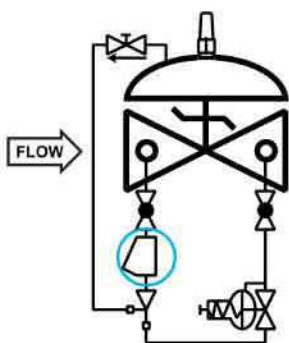

EXAMPLE: Shown here on a MODEL 127-3 Pressure Reducing Valve

**MAINTENANCE**

Routine cleaning and checking of the Y-Strainer will aid in keeping the control valve functioning properly. Pilot system isolation ball valves are supplied on valves equipped with the Model 159 Y-Strainer. These allow flushing of the screen through the blow off port, or removal of the screen itself for manual cleaning.

**DESCRIPTION**

The Model 155 Visual Indicator is a device that enables the user to determine the extent of opening of a control valve. It consists of an adaptor threaded into the center port of the valve bonnet, a rod threaded into the main valve stem, a sealing O-ring, and a protective clear plastic housing. The indicator rod moves as the valve opens and closes. It may be installed on virtually any OCV control valve, and can be done so without any disassembly of the valve itself.

**WHERE USED** - Standard on Series 94 Check Valves, Series 3330 Altitude Valves, and Series 22 Digital Control Valves. Optional on any other valve not employing a limit switch or position transmitter.



**MODEL 155 MATRIX**

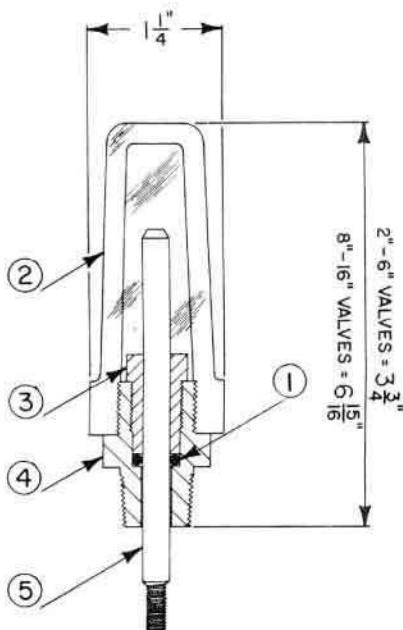

MATERIAL	PART NO. (BRASS ADAPTOR)	PART NO. (STAINLESS ADAPTOR)	VALVE TRAVEL (FULL STROKE)
1 1/4" - 1 1/2"	255100	255700	3/8"
2"	255100	255700	1/2"
2 1/2"	255100	255700	3/4"
3"	255100	255700	1"
4"	255101	255701	1 3/8"
6"	255102	255702	1 1/2"
8" - 10"	255103	255703	2 1/2"
12"	255104	255704	3"
14" - 16"	255105	255705	3 1/2", 4"
24"	255109	255709	6"

ITEM	DESCRIPTION
1	O-Ring
2	Housing
3	Bushing
4	Adaptor
5	Stem

**SCHEMATIC SYMBOL**

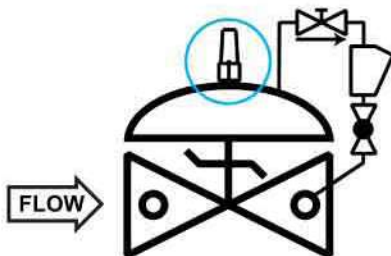

The Model 155 is shown on OCV Valve Schematic as:



EXAMPLE: Shown here on a Model 94-1 Check Valve

**MATERIALS**

- Indicator Rod: Monel
- Adapter: Brass (std.), Stainless Steel (optional)
- Housing: Butyrate (1 1/4" - 6") Acrylic (8" and larger)
- O-Ring: Viton® (std.) Buna-N, EPDM (optional)

**Valve Position Indicator 155**



# OCV<sup>®</sup> FLUID SOLUTIONS<sup>LLC</sup>



matholding group