

A.R.I. D-070P-Q PN 10 / 16

Dynamic Combination Air Valve and Pressure Relief Valve

The following is a step-by-step narrated description of the A.R.I. D-070P-Q Dynamic Combination Air Valve and Pressure Relief Valve installation, operation and maintenance processes.

The A.R.I D-070P-Q valve fulfils two major tasks: The air valve component serves as a Combination Dynamic Air Valve that operates without a float and utilizes the rolling diaphragm principle, while the Pressure Relief component quick-releases excessive line pressure and maintains a safe and gradual closing.

The A.R.I D-070P-Q solution protects the pipeline from excessive pressure, eliminates bursts and water loss:

- It prevents up-surges by discharging initial pressure in controlled and gradual manner.
- It prevents the energy loss caused by air pockets, by discharging air from pressurized water lines.
- When vacuum occurs, it admits air into the system for impending down-surges.
- In cases of extreme line pressure, it quickly releases the excessive pressure to the atmosphere.

The A.R.I D-070P-Q is designed for water systems that operate within the pressure and temperature framework of the model's specifications table. Please consult Aquestia for products designed for other wastewater or hazardous liquids systems.



Table of Contents

1. Safety Instructions.....	3
2. Installation.....	6
3. Operation	10
4. Troubleshooting	11
5. Assembly Bom Table and Drawing – 2”	12
6. Assembly Bom Table and Drawing – 3”	13
7. Periodic Maintenance	14
Releasing Pressure.....	14
Assembly and Testing for Leaks	14

Disclaimer

This document is an Installation, Operation and Maintenance (IOM) manual for Aquestia Ltd. The information enclosed herein contains restricted, privileged, proprietary and confidential information, intended only for usage by authorized Aquestia technicians. If you are not a qualified technician, you must not take any action in reliance upon this document, unless otherwise permitted in writing by Aquestia

Aquestia has made every effort to ensure that this document is accurate; Aquestia disclaims liability for any inaccuracies or omissions that may have occurred.

All the procedures, drawings, pictures and/or any other information provided in this document are presented as general information only; they can be altered, removed or changed without Aquestia's prior written approval. Aquestia makes no commitment to update or keep the information in this document current and/or up-to- date, and reserves the right to make improvements, alterations and/or modifications to this document and/or to the products described in this document, at any time without providing any notice with respect thereto. Nothing in this Disclaimer derogates in any way whatsoever from the confidential nature of any document enclosed hereto, including for avoidance of doubt, any mistake or clerical error or other error. None of the procedures provided in this Disclaimer and/or in any document enclosed hereto may be used in any form or by any means without the prior written consent from Aquestia If you received this Disclaimer and/or in any document enclosed hereto in error or by mistake or if this Disclaimer and/or in any document enclosed hereto is not intended for you, please notify Aquestia in writing immediately.

Aquestia assumes that all users understand the risks involved within this Disclaimer and/or in any document enclosed hereto.

Aquestia accepts/assumes no liability whatsoever, whether caused by: accessing and/or relying upon this Disclaimer and/or in any document enclosed hereto including without limitation any links, procedures or materials.

shall NOT assume any liability for any costs, direct or indirect, including loss of income, loss of profits and/or goodwill, legal actions and/or damages of any kind whatsoever including any, damages accidents, equipment damage or bodily injury resulting from and/or related to any of the following:

- product has not been duly installed and thereafter maintained in strict compliance with its designated Maintenance Instructions and/or any other installation and operation manuals provided by Aquestia for the product and/or applicable ordinances and/or codes;
- Repairs made in and to the products by personnel not authorized by Aquestia
- Maintenance or repairs using parts or components other than those specified by Aquestia and in their original condition.
- Operating the products in ways other than the operating procedures described in the manuals provided by Aquestia, or resulting from not following the cautionary remarks and warnings in the product manual.
- Improper storage, workplace conditions and environmental conditions which do not conform to those stated in the Product manual.
- Fires, earthquakes, floods, lightning, natural disasters, or acts of God.

Aquestia does not warrant and hereby disclaims any express or implied warranties that the product will work properly in environments and applications other than its original design purpose, and makes no warranty and representation, either implied or expressed, with respect to the quality, performance, merchantability, or fitness for any other particular purpose.

Except as provided herein and to the full extent permitted by law, Aquestia shall not be responsible and/or liable for direct, special, incidental or consequential damages or loss resulting from any breach of the above or under any other legal theory.

This document does not replace any certified drawing, procedure or information provided by Aquestia in reference to a specific customer, site or project. All rights reserved.

1. Safety Instructions

General

1. Aquestia products always operate as components in a larger system. It is essential for the system designers, installers, operators and maintenance personnel to comply with all the relevant safety standards.
2. Installation, operation or maintenance of the product should be done only by qualified workers, technicians and/or contractors using only good engineering practices, complying with and observing all conventional safety instructions in order to minimize risk and/or danger and/or hazard to workers, the public or to property in the vicinity in accordance with all relevant local standards.
3. Extra safety considerations should be taken with hot and hazardous liquids or in hazardous environments' applications to avoid bodily/physical harm and damage to public or private property.
4. All individuals installing operating and/or handling the products including all workers should at all times adhere with the occupational safety and health (OSH) instructions and wear safety helmets, goggles, gloves, and any other personal safety equipment required by the local standards and regulations.
5. Use only appropriate standard tools and equipment operated by qualified operators when installing, operating and maintaining the product.
6. Prior to installation, operation, maintenance or any other type of action carried out on the product, read carefully the safety, installation and operation instructions of the product.
7. **Please note:**
 - Pressurized fluid and/or gas may be discharged from the product without prior warning. Make sure that the product's outlet port is not directed toward electrical elements (pumps) or people.
 - The pressurized fluid and/or gas that can be discharged from the product may create high noise levels. Take this into consideration when installing the product in areas sensitive to noise.
8. Always open and close valves slowly and gradually.
9. Please note that the maximum working pressure indicated at the product's specifications table doesn't include pressure changes caused by water hammer and pressure surge effects. Use the product only according to its designated pressure rate specifications.
10. Use the product only for its intended use as designed by Aquestia. Any misuse of the product may lead to undesired damages and may affect your warranty coverage. Please consult with A.R.I. prior to any non-regular use of this product and make no change or modification to the product without a prior written consent to be provided by Aquestia at Aquestia's sole discretion.
11. Please note that Aquestia shall **NOT** assume any liability with respect to any damage losses and/or expenses caused to any person and/or property whatsoever unless the product has been duly installed and thereafter maintained in strict compliance with its designated maintenance Instructions and/or any other installation and operation manuals provided by A.R.I. for the product and/or applicable ordinances and/or codes.

Handling

1. Shipping and handling the product must be done in a safe and stable manner and in accordance with the relevant standards and regulations.
2. Storage should be in the original delivery crates or cases. Storage should be off the ground in a clean, dry indoor area.
3. For lifting and positioning the product, use only approved lifting equipment operated by authorized employees and contractors.
4. Prior to the installation visually verify that the product was not damaged during shipment to the installation site.

Installation

1. Install the product according to the detailed Installation Instructions provided with it by Aquestia and according to the description given in this manual.
2. The user should install a manual Isolation Valve under the product's inlet port.
3. In all installation sites the user should enable good visibility and verify that the work and auxiliary equipment used are done in accordance with the relevant local authorized standards. Extra safety considerations should be taken on hazardous environment sites.
4. Check and re-tighten the bolts connecting the product to the pipeline during commissioning and before operating the product for the first time.

Commissioning and operation

1. Read carefully the operation instructions prior to any attempt to operate the product.
2. Observe the safety stickers on the product and never perform any operation contradicting the instructions given.
3. In order to achieve maximum performance and smooth operation of the product it is crucial to perform the startup and first operation procedures exactly as described in this manual.
4. In cases where formal commissioning procedure is required it should be done by an authorized Aquestia technician prior to the first operation of the product.

Maintenance

Before any maintenance or non-regular operation please read the following:

1. Servicing the product should be done only by qualified technicians for this type of work.
2. Make sure that you know the exact type of the system's fluid. Act accordingly and comply with all the relevant standards and regulations set for handling this type of fluid.
3. Before disconnecting the product from the system and before releasing the residual pressure do **NOT**:
 - loosen or unscrew the product bolts;
 - remove any protection cover;
 - open any service port.
4. Before any maintenance or non-regular operation shut off the Isolation valve and release the residual pressure:
 - A. For air valves with pressure release outlet, slowly open the pressure release plug or the ball valve and make sure that all pressure is released. Please note that some air release valves, especially the waste water models, may contain significant volume of compressed gas with accumulated energy!
 - B. For air valves without a pressure release outlet, slowly unscrew the flange bolts until all the pressure is released from the valve.
5. Make sure the air valve is empty of all liquid prior to commencing maintenance.
6. Remove the product from the line only after ensuring that internal pressure has been released.
7. Place warning signs around the work area as required by the local standards and procedures.
8. Inspect the product's safety stickers and replace any damaged or faded sticker.
9. Manual cleaning of the product and/or its components using high water pressure or steam should be performed in accordance with its specific cleaning instructions, the local standards and regulations and without endangering the operator or the vicinity
10. Manual cleaning of product and/or its components using acid or other chemical agents should be performed in accordance with the specific cleaning instructions, the relevant safety instructions for using that chemical as given by its supplier, the local standards and regulations and without endangering the operator or his vicinity.
11. For products used in potable water systems if it is required to disinfect the product, do so according to the local water authority standards and regulations before putting the product into service.

Before returning to regular operation

1. Re-assemble any protection covers or protection mechanisms removed during service or maintenance operations.
2. Make sure that all the tools, ladders, lifting devices, etc. used during the maintenance procedures are taken away from the product area and stored.
3. Remove grease and fat material residues in order to avoid slipping.
4. In order to return the product to regular operation, follow the First Start-up Operation instructions as detailed in your user manual.

2. Installation

Important: Before performing any work on the product make sure that all workers on site are familiar with the safety instructions and the relevant local and general safety instructions and work regulations.

2.1. Installation Recommendations



- Single D-070P-Q downstream of a deep well pump acting as circulation valve and high capacity air valve. The Isolating Valve handle is installed at 45° to the Air Valve outlet.



- Two D-070P-Q units, upstream of a pressure sustaining valve; acting as pressure relief, continuous air release and a vacuum breaker. The Isolatioin Valve wheel is installed at 45° to the Air Valve outlet.



- Two D-070P-Q units:
 1. Upstream of an irrigation head, acting as a pressure relief, continuous air release and a vacuum breaker
 2. Downstream of a pressure reducing valve, acting as pressure relief and a continuous air release

2.2. Conventions and Measurements

This paragraph presents and explains the terms and measurements used for the Installation process.

D = Diameter of pipeline
 d = diameter of riser
 H = Height of riser on the pipeline
 (Measured from crown of pipeline)

- For pipelines up to 12" (300mm) in diameter (D), the Air Trap diameter (d) should be the same as the pipeline diameter.
- For larger pipelines of up to 60" (1500mm) in diameter (D), the Air Trap diameter (d) should be 60% of the pipeline diameter.
- For larger than 60" (1500mm) pipelines (D), the Air Trap diameter (d) should be 35% of the pipeline diameter.
- The Air Trap length (H) should allow easy access to the air valve from below and should be at least 6" (150mm).

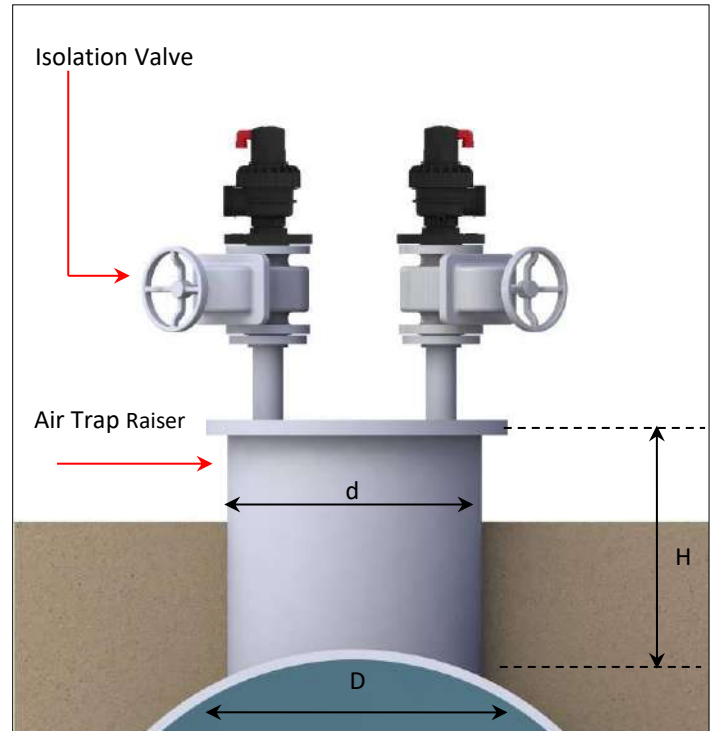

The D-070P-Q components:

1. Adjustment screw
2. Pilot
3. Pressure gauge port, or pressure check point
4. Pressure release outlet P1
5. Air release outlet
6. Air discharge / intake
Pressure release outlet P2



2.3. Installation Instructions

1. Flush the system before installing the product to avoid any debris or sharp objects getting into the valve.
2. Carefully remove the product from the shipping package. Unload all air valves carefully to a sturdy level surface taking care not to drop them.
3. Install an isolating valve below the valve, connected by a riser to the crown of the pipe.
4. The D-070P-Q valve should be installed vertically on a riser on the crown of the pipeline.
5. Mount the valve carefully on the rubber gaskets of the isolating valve.
6. Place washers on each of the bolts & nuts that connect the valve flange to the isolating valve flange.
7. Tighten all the bolts and nuts using the crossover method.
 - a. The closure tightness of the bolts and nuts shall be according to the standard torque for their specific size.
 - b. Use ring wrench keys for the closing and opening of all bolts of the air valve (including the flange bolts).
8. It is recommended that the valve be easily accessible as well as clearly marked to prevent damage.

2.4. Directions for Discharge Outlet D-070P-Q Air Valve

3. It is recommended to leave the discharge outlet completely open and unhindered:
 - a. Avoid directing the discharge outlet opening in the direction of workers, bystanders or animals.
 - b. Avoid directing the discharge outlet opening in the direction of vulnerable equipment that can be damaged, such as electrical equipment, unstable structures, etc.
4. If a drain pipe must be installed to direct the outlet discharge away from sensitive areas, please follow the recommended drawing (do not use flexible pipe):

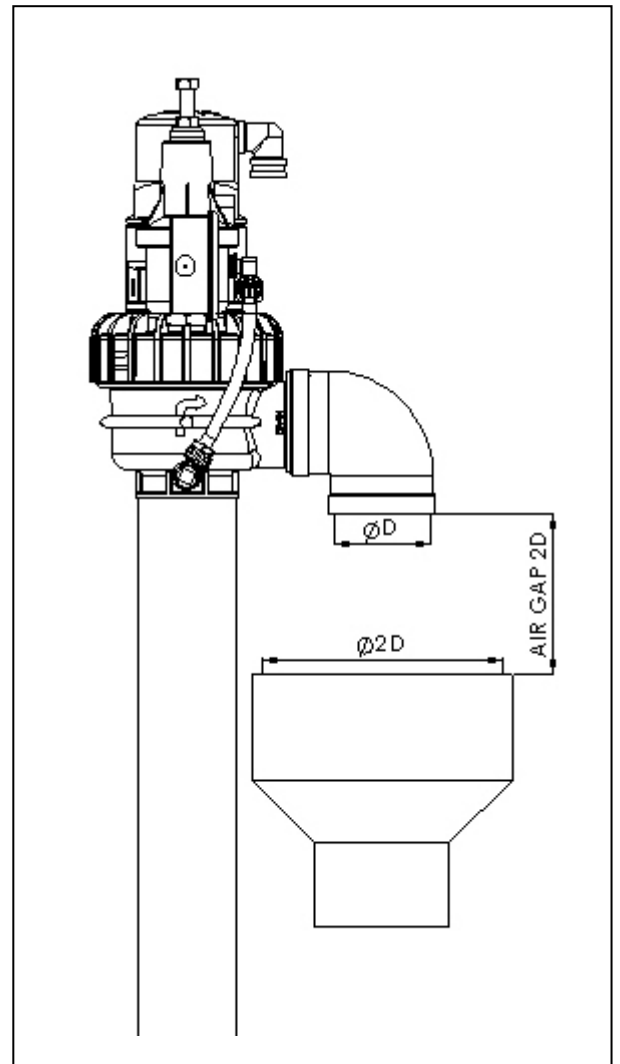

D = Diameter of the air valve

2.5. Initial Start-up – The Pressure Relief component of the D-070-Q

It is recommended to set the relief pressure level at 0.5bar above the working pressure of the system

1. Make sure that the upstream isolation valve is closed [4].
2. Slightly open the upstream isolation valve [4], water starts to flow to the valve.
3. Wait for the valve to stop discharging water.
4. Turn the adjusting screw [3A] counter-clockwise until water begins to drip from the pilot port #4.
5. Turn the adjusting screw [3A] clockwise half turn.
6. Make sure that there is no water coming out from the pilot port #4.
7. When the required pressure is reached, prevent the adjusting bolt [3A] from turning, and turn the locking nut [3B] clockwise until it touches the pilot bonnet. Tighten the nut carefully.
8. Fully open the upstream isolation valve [4].

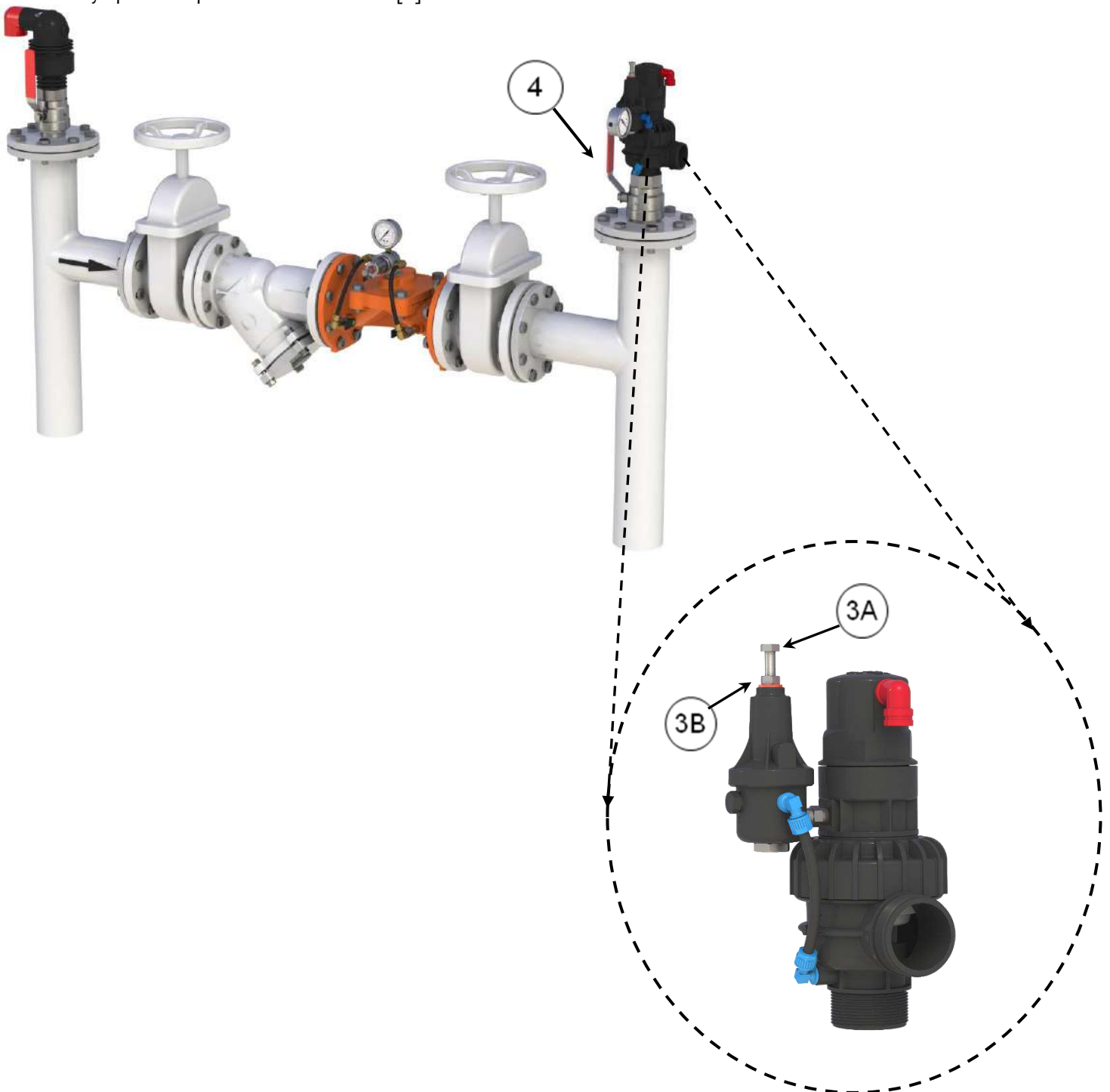

3. Operation

At the startup of the water system, the pipeline begins to fill with water; air flows in the pipeline and enters into the dynamic air valve, raising the rolling diaphragm sealing assembly to the open position.

Air is then discharged, mainly through the lower chamber large orifice as well as small amounts of air released through the upper chamber operating valve orifice. When the flowing water enters the dynamic air valve, it fills the lower chamber and some of it flows up through the orifice chamber and enters into the upper operating chamber, raising the float of the operating valve which rolls the sealing mechanism to its sealed position.

Pressure develops inside the upper operating chamber, bringing about a controlled lowering and sealing of the rolling diaphragm sealing assembly, which, in turn, closes the lower chamber large orifice.

NOTE: It is recommended to attach a drainage pipe to the external threads on the large orifice outlet as some water will be expelled from the orifice during this closure stage. The size of the drainage pipe should be, at a minimum, the diameter of the outlet and the unattached end should remain open to the atmosphere.

At this stage, only the automatic air release component continues to work and releases air through its small orifice. With a reduction in line pressure, during drainage or shut-off, the pressure in the valve is reduced and is less than the outside atmospheric pressure. The vacuum created causes the rolling diaphragm sealing assembly to rise up into its open position, opening the lower chamber large orifice and allowing the intake of air from the atmosphere into the system.

In cases of extreme line pressure development, the quick pressure relief pilot quickly releases the excessive pressure to the atmosphere and maintains a safe and gradual closing.

No.	Description	QTY.
1	Main Valve	1
2	Pressure gauge	1
3	Ultra Q. pressure relief Pilot valve, 3-Way	1

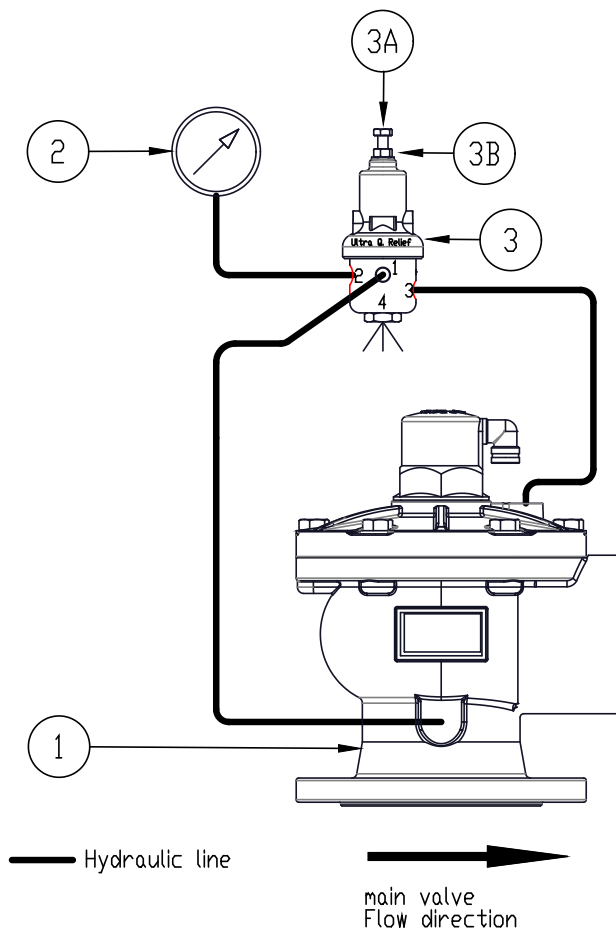

4. Troubleshooting

Problem	Cause	Check	Solution
Leakage from the Discharge Outlet	A. Debris or scale buildup on the Rolling Seal (Number [3] on the BOM table). B. Torn Rolling Seal.	Leakage under pressure from the discharge outlet	Follow instructions in the Maintenance of the Pilot Operating Valve section of this document.
	A. Debris or foreign object caught in the Rolling Diaphragm Sealing Assembly (Number [10] on the BOM table).	Leakage under pressure from the discharge outlet	Follow instructions in the Maintenance of the Dynamic Valve Body section of this document.
	A. Damaged Sealing Assembly or Diaphragm (Number [10] on the BOM table).	Leakage under pressure from the discharge outlet	Follow instructions in the Maintenance of the Dynamic Valve Body section of this document.
Valve does not open	1. The inlet pressure is too low	1. Check the inlet pressure	1. Make sure that the water supply (or the pump) is on.
	2. The preset pressure is too high	2. Check the pilot's adjustment	2. Readjust the pilot's setting point see paragraph 2.5
Valve does not close	1. Debris on the sealing seat	1. The valve is constantly discharging a small amount of water to the downstream	2. Follow instructions in the Maintenance of the Dynamic Valve Body section of this document.
	A. Damaged Sealing Assembly or Diaphragm (Number [10] on the BOM table).	Leakage under pressure from the discharge outlet	Follow instructions in the Maintenance of the Dynamic Valve Body section of this document.
	3. Blocked pilot	4. No reaction while calibrating according to paragraph 2.5	1. Contact Aquestia's field service
	5. The preset pressure is too low	1. Check the pilot's adjustment	2. Readjust the pilots setting point see paragraph 2.5

5. Assembly Bom Table and Drawing – 2”

1	Discharge Elbow
2	Body
3	Rolling Seal
4	Pilot Float Assembly
5	Pilot Float Assembly
6	O-ring
7	Adaptor Assembly Body
8	O-ring
9	Cover (Locking Ring)
10	Adaptor supporting Ring
11	N/A
12	Body
13	P-31U Pilot
14	8mm Tube

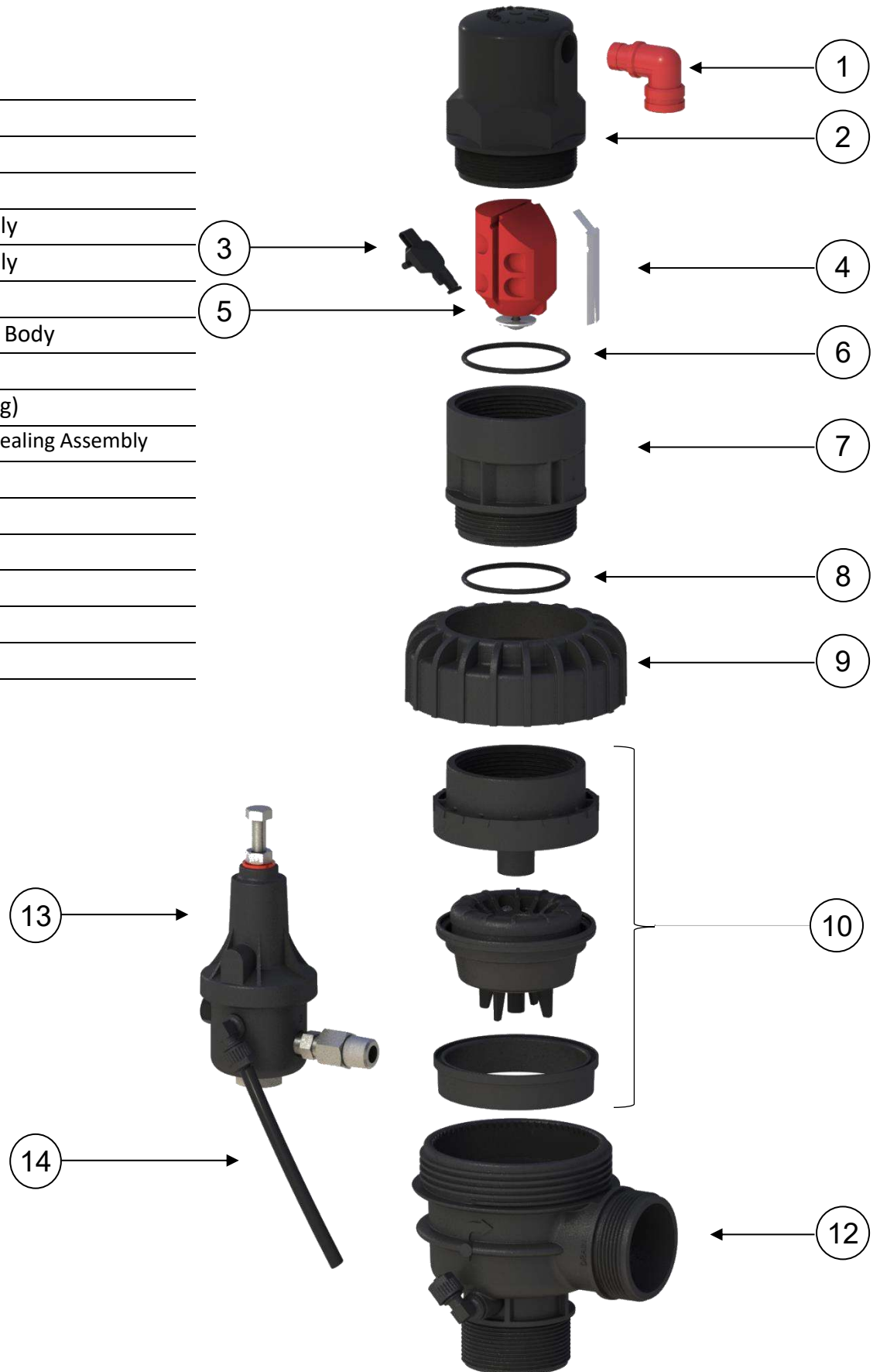

6. Assembly Bom Table and Drawing – 3”

1	Discharge Elbow
2	Body
3	Rolling Seal
4	Clamping Stem
5	Pilot Float Assembly
6	O-ring
7	Adaptor Assembly Body
8	O-ring
9	Cover
10	Rolling Diaphragm Sealing Assembly
11	Bolt, Nut & Washer
12	Body
13	P-96Q Pilot
14	8mm Tube

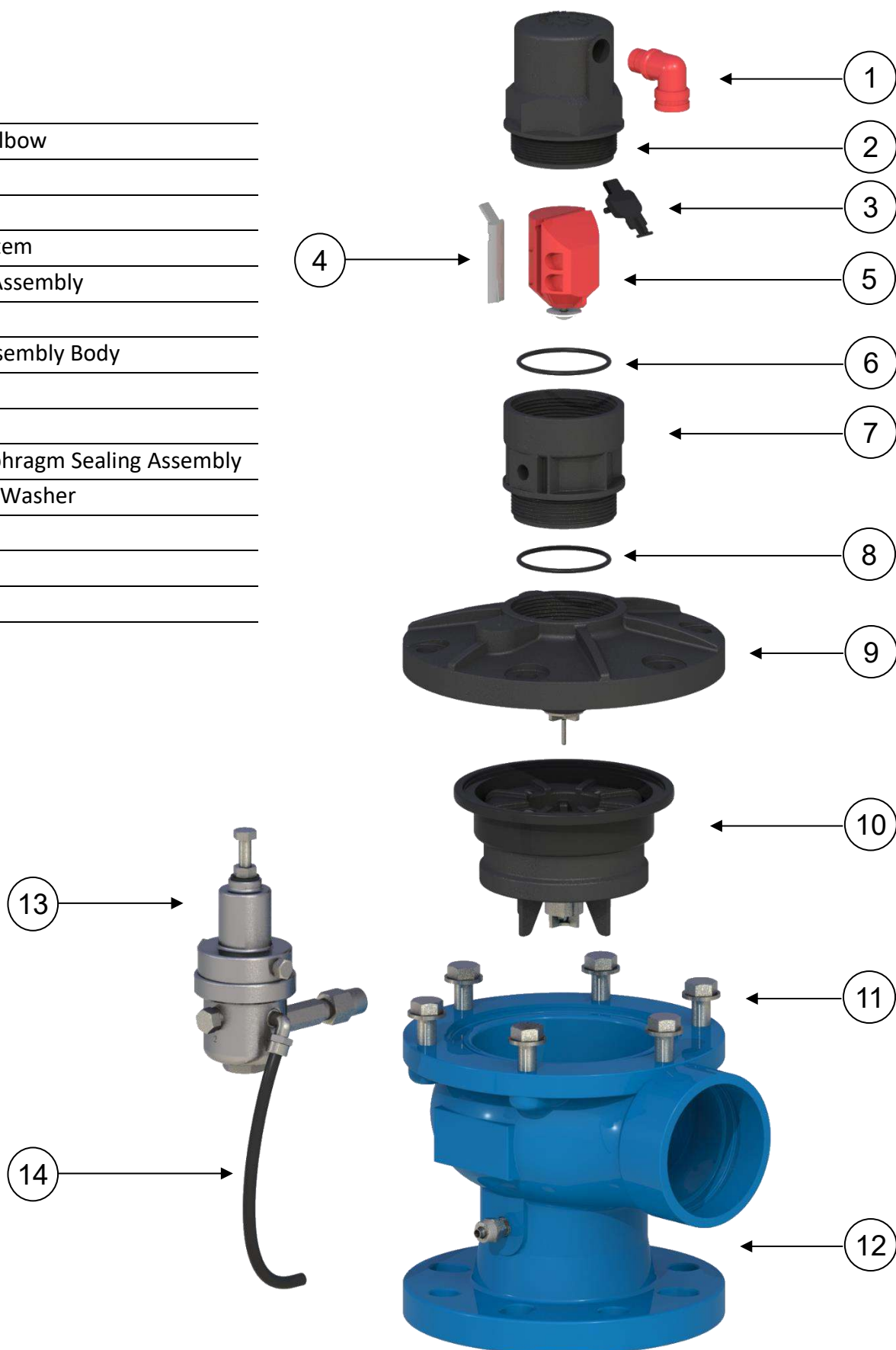

7. Periodic Maintenance

Please note that the periodic maintenance of the air valve is an integral part of the proper pipeline maintenance regime; it should be maintained at least once a year in accordance with the quality and composition of the fluid in the system.

Important: Before performing any work on the air valve, make sure that all workers on site are familiar with the Safety Instructions section of this document and with all the relevant local and general safety instructions, standards and work regulations.

Releasing Pressure

- Shut the isolating valve located on the riser under the air valve.
- Carefully release the pressure and drain the air valve
- Important: Discard liquid to comply with local regulations

MAINTENANCE OF THE OPERATING VALVE

1. Unscrew the Body (2) from the Operating Valve.
2. Remove the Clamping Stem (4) and the Float (5). Wash the inside of the Body, the Clamping Stem, the Rolling Seal (3), and the O-ring (6) under clean running water.
3. Gently wash and clean the sealing area inside the valve Body.
4. Visually check the O-Ring for any cracks or tears. Replace if needed.
5. Check that the Rolling Seal is intact (not torn or cracked) and is positioned precisely in the middle of its groove in the Float. Replace if needed.
6. The disc at the bottom of the Pilot Float Assembly (5) should be loose and move freely. Do not tighten the holding screw.
7. Reassemble the Operating Valve after maintenance

MAINTENANCE OF THE DYNAMIC VALVE BODY

1. Follow instructions in the above section:
2. Unscrew and remove the Bolts (11) that connect the Cover (9) to its Body (12).
3. Remove the Rolling Diaphragm Sealing Assembly (10) from the Body.
4. Wash the Body and the Cover (9) under clean running water in order to remove coarse grime or accumulated scale.
5. Wash the Rolling Diaphragm Sealing Assembly (10) and check the rubber parts for any cracks or tears. Replace the entire Rolling Diaphragm Sealing Assembly unit if damage is detected. Do not open screws of the assembly under any circumstances.
6. Make sure that the passage hole at the bottom of the Rolling Diaphragm Sealing Assembly (10) is clean and open.
7. Make sure that there is no dirt or debris around the sealing area of the dynamic valve Body (12).

Assembly and Testing for Leaks

- Reassemble the Rolling Diaphragm Sealing Assembly into the Body in reverse order, fasten and tighten all Bolts.
- Reconnect the Quick Pressure Relief Assembly and the Air Valve Pilot to the air valve.
- Slowly open the Isolating Valve beneath the air valve, making sure that there are no leaks.
- Check the air valve for proper operation.
- Repair paint damage to the outer body if needed.